

TYPE ST

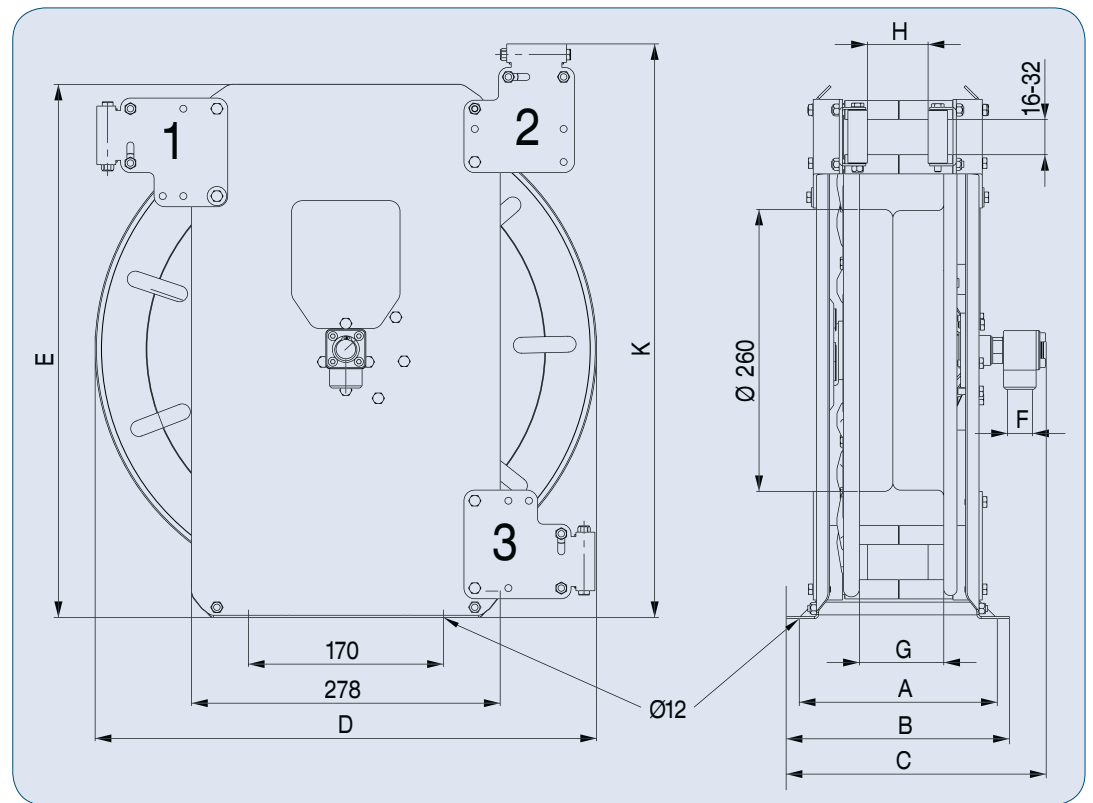

RS		Slanglengte in mm				F			Afmetingen in mm								
Art.-Nr.	Type	ø15	ø20	ø25	ø30	mm	Zoll	bar	kg	A	B	C	D	E	G	H	K
3/8" (DN10)																	
460300	ST14/10	poedercoating	14	12		10	3/8"	300	13	176	206	239	400	440	75	48	470
460302	ST14/10e	rvs	14	12		10	3/8"	300	13	176	206	239	400	440	75	48	470
460307	ST20/10	poedercoating	20	17		10	3/8"	300	16	176	206	239	460	500	75	48	530
460308	ST20/10e	rvs	20	17		10	3/8"	300	16	176	206	239	460	500	75	48	530
460310	ST20/10ep	verzinkt	20	17		10	3/8"	300	16	176	206	239	460	500	75	48	530
460316	ST30/10	poedercoating	28	10		10	3/8"	300	18	226	256	304	460	500	125	106	530
460313	ST30/10e	rvs	28	10		10	3/8"	300	18	226	256	304	460	500	125	106	530
460315	ST40/10/2	poedercoating	40	37		10	3/8"	300	22	276	306	339	460	500	182	152	530
460320	ST40/10/2e	rvs	40	37		10	3/8"	300	22	276	306	339	460	500	182	152	530
460329	ST60/10/3e	rvs	57	50		10	3/8"	300	32,5	376	406	454	460	500	282	252	530
1/2" (DN12)																	
460306	ST14/12e	rvs		12	8	12	1/2"	200	13	176	206	239	400	440	75	48	470
460309	ST20/12e	rvs		17	13	12	1/2"	200	16	176	206	239	460	500	75	48	530
460314	ST30/12e	rvs		25	22	12	1/2"	200	18	226	256	304	460	500	125	106	530
460326	ST40/12/2e	rvs		37	12	12	1/2"	200	22	276	306	339	460	500	182	152	530
3/4" (DN19)																	
460311	ST20/19	poedercoating			10	7	3/4"	200	17	176	206	254	460	500	75	48	530
460312	ST20/19e	rvs			10	7	3/4"	200	17	176	206	254	460	500	75	48	530
460330	ST40/19/1	poedercoating			20	18	3/4"	200	19	276	306	354	460	500	182	152	530
460331	ST40/19/1e	rvs			20	18	3/4"	200	19	276	306	354	460	500	182	152	530
460335	ST40/19/2	poedercoating			36	30	3/4"	200	25	376	406	454	460	500	282	252	530
460336	ST40/19/2e	rvs			36	30	3/4"	200	25	376	406	454	460	500	282	252	530