

EQUIPAGGIAMENTI
TECNICI
LAVAGGIO

TESTINE ROTANTI
MOD. M25E ASPIRANTE



4 13

12.9413.00

20/12/05

M25E

25.4350.00 (I)-220Vca
25.4350.25 (I)-24Vca
25.4350.60 (USA)-110Vca
25.4350.24 (AUS)-240Vca

MANUALE D'ISTRUZIONE
GENERAL INTRUCTION BOOK



TESTINA ELETTRICA PULIZIA
CONTENITORI E BOTTI.
ASPIRAZIONE INTERNA INTEGRATA.

- Testina per il lavaggio di contenitori e botti con sistema di aspirazione e scarico esterno del liquido utilizzato per il lavaggio.
- Portata ridotta, alta pressione, elevata forza di impatto.
- Copertura orbitale completa degli interni.
- Minimo ingombro radiale che ne permette l'introduzione attraverso passaggi ridotti.
- Alimentazione elettrica a bassa tensione.
- Costruzione in acciaio inox.
- Idonea per impiego settore alimentare.

ATTENZIONE !

- La Testina STANDARD è fornita di guarnizioni (DINAMICHE) in PTFE + O-Ring EPDM.
- Lubrificare esclusivamente con GRASSO SILICONICO codice: 14.6552.00
- Per l'utilizzo di liquidi detergenti, additivi chimici ecc. non compatibili con le guarnizioni standard è indispensabile contattare il nostro UFFICIO TECNICO.
- A richiesta le guarnizioni (DINAMICHE) O-RING sono disponibili anche in diverso materiale, NBR-FFKM(kalrez)-FKM(viton).
- Le guarnizioni (STATICHE) sono in FKM (viton).

ELECTRICAL HEAD DESIGNED TO
CLEAN SMALL TANKS AND BARRELS,
EQUIPPED WITH SUCTION SYSTEM.

- Tank cleaning head ideal for cleaning all types of tanks and barrels. It washes and, at the same time, siphons off the water used during the cleaning process.
- Reduced flow, high pressure, high cleaning impact.
- Complete orbital coverage of all interior surfaces.
- Reduced spray turret that fits through small barrel and tank openings.
- Low tension electric power.
- Stainless steel construction.
- Suitable for utilization in food industry.

ATTENTION !

- The STANDARD Tank cleaning head is supplied with seals (DYNAMIC) in PTFE + O-Ring EPDM.
- Lubricate ONLY with SILICONE GREASE P/N: 14.6552.00
- For use with Detergent liquid, Chemical additives etc that are not compatible with the standard seals, it is essential to contact our TECHNICAL OFFICE for further information.
- On request, the O-RING seals (DYNAMIC) are available in different materials such as NBR-FFKM(kalrez)-FKM(viton).
- The STATIC seals are in FKM (viton).

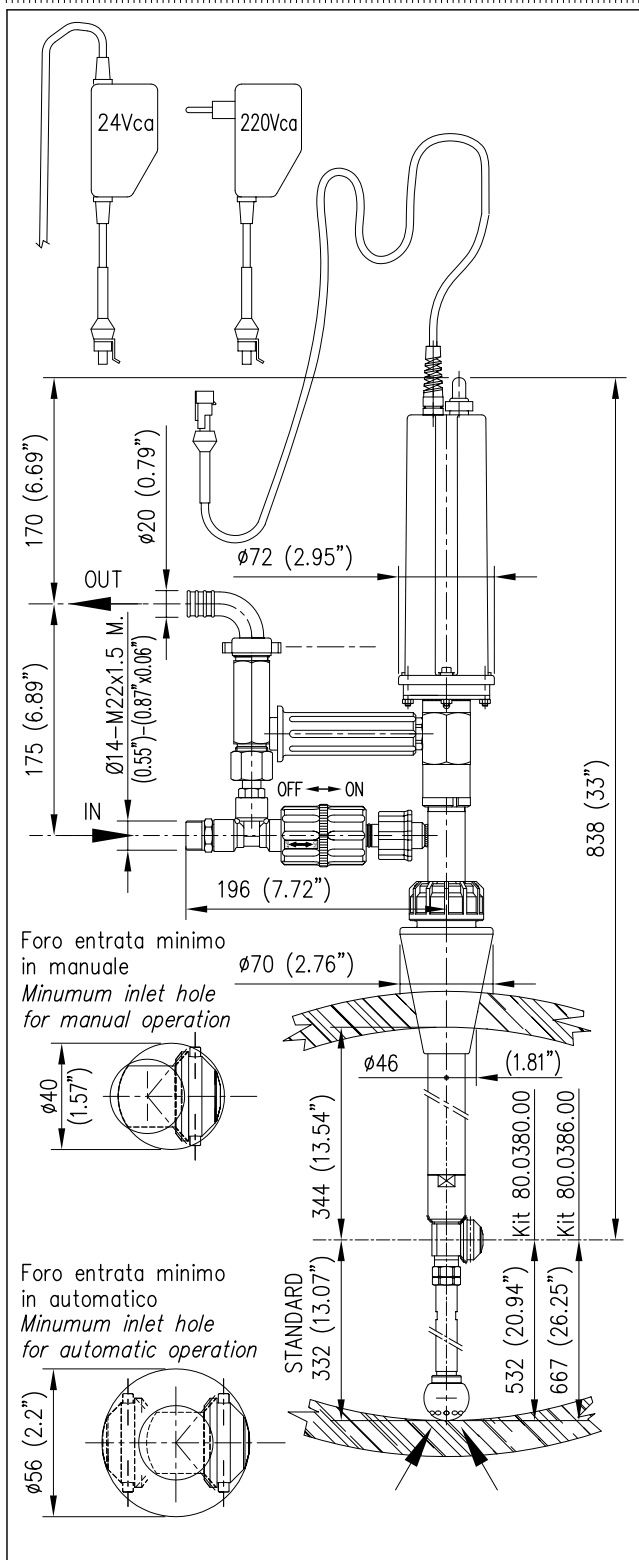

	A	B max.
-Testina standard	$\phi 46$	$\phi 730$
-Testina + Kit 80.0380.00	$\phi 50$	$\phi 940$
-Testina + Kit 80.0386.00	$\phi 50$	$\phi 1070$

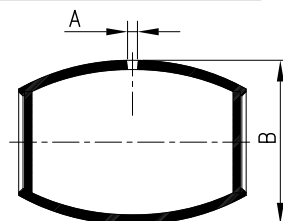

ATTENZIONE: NON UTILIZZARE
L'APPARECCHIO PRIMA DI AVER LETTO
QUESTO MANUALE DI ISTRUZIONE

CAUTION: DO NOT USE THE
CLEANING HEAD BEFORE HAVING READ
THE INSTRUCTION BOOK

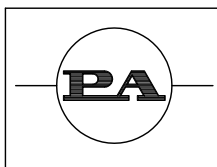

EQUIPAGGIAMENTI
TECNICI
LAVAGGIO

CABEZALES ROTANTES
TÊTE TOURNANTE
MOD. M25E ASPIRANTE
ASPIRANTE

(E)	4	13
(F)		
12.9413.50		20/12/05

M25E

- 25.4350.00 (I)-220Vca
- 25.4350.25 (I)-24Vca
- 25.4350.60 (USA)-110Vca
- 25.4350.24 (AUS)-240Vca

MANUAL DE INSTRUCCIÓN

MANUEL D'UTILISATION

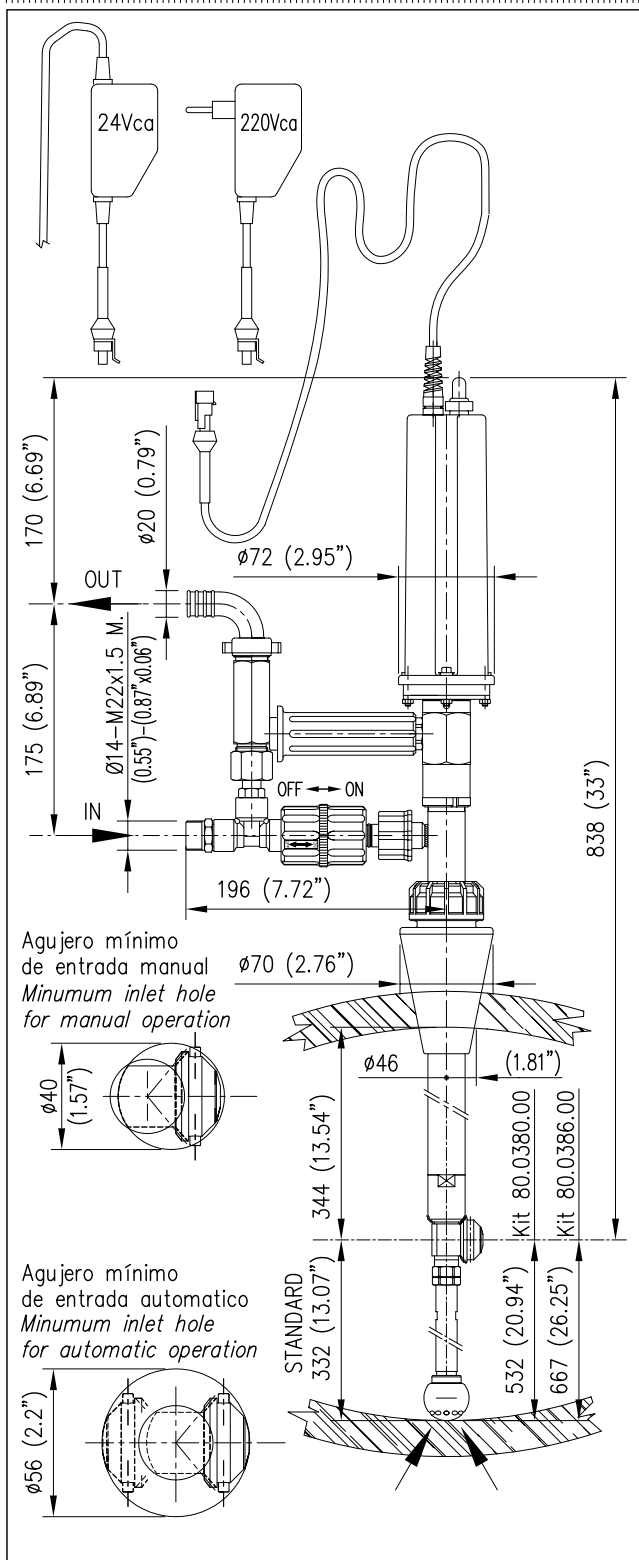

CABEZAL ELECTRICO POR LA LIMPIEZA DE CONTENEDORES Y TONELES
ASPIRACION INTERNA INTEGRADA

- Cabezal por el lavado de contenedores y toneles con sistema de aspiración y descarga del líquido empleado por el lavado.
- Cobertura orbital completa de los interiores.
- Caudal reducto, alta presión, elevada fuerza de impacto.
- Dimensiones reducidas de la parte porta-boquilla para permitir el lavado de contenedores con pequeñas bocas de paso.
- Alimentación eléctrica a baja tensión.
- Construcción en acero inox AISI 304.
- Idónea por la utilización en el sector alimentario.

ATENCIÓN !

- El cabezal ESTÁNDAR está equipado de guarniciones (DINÁMICAS) en PTFE + EPDM.
- Lubrifcar exclusivamente con GRASA SILICÓNICA código: 14.6552.00
- Para la utilización de líquidos detergentes, aditivos químicos etc. no compatibles con las guarniciones estándar es indispensable de contactar nuestra OFICINA TÉCNICA.
- Contra demanda las guarniciones (DINÁMICAS) ANILLOS TÓRICOS están aun disponibles en otros materiales: NBR-FFKM (kalrez), - FKM (viton).
- Las guarniciones (STÁTICAS) son en FKM (viton).

TÊTE ÉLECTRIQUE NETTOYAGE RÉCIPIENTS ET BARRIQUES, AVEC SYSTÈME D'ASPIRATION ET ÉVACUATION

- Tête pour le nettoyage de récipients et barriques avec système d'aspiration et avec évacuation à l'extérieur de l'eau utilisée pour le nettoyage.
- Couverture orbitale complète des surfaces intérieures.
- Bas débit, haute pression=puissance de nettoyage élevée.
- Dimensions réduites de la partie porte-buses, ce qui permet le nettoyage de récipients avec petits trous de passage.
- Alimentation électrique à basse tension.
- Construction en inox AISI 304.
- Adéquate pour utilisation dans l'industrie alimentaire.

ATTENTION !

- La tête de lavage STANDARD est douée de joints (DYNAMIQUES) en PTFE + EPDM.
- Lubrifiez exclusivement avec de la GRAISSE SILICONIQUE référence: 14.6552.00
- Pour l'utilisation de liquides détergents, additifs chimiques etc. non compatibles avec les joints standard il est indispensable de contacter notre SERVICE TECHNIQUE.
- Sur demande les JOINTS TORIQUES (DYNAMIQUES) sont disponibles en d'autres matériels, à savoir : NBR, FFKM (kalrez), FKM (viton).
- Les joints (STATIQUES) sont en FKM (viton).

	A	B max.
-Testina standard	$\phi 46$	$\phi 730$
-Testina + Kit 80.0380.00	$\phi 50$	$\phi 940$
-Testina + Kit 80.0386.00	$\phi 50$	$\phi 1070$

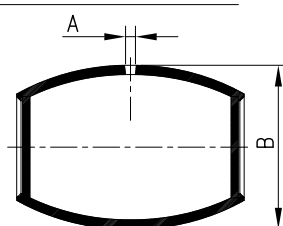

ATENCIÓN : NO UTILIZAR EL APARATO ANTES DE HABER LEÍDO ESTE MANUAL DE INSTRUCCIÓN

ATTENTION : N'UTILISEZ PAS L'APPAREIL AVANT D'AVOIR LU CE MANUEL D'UTILISATION

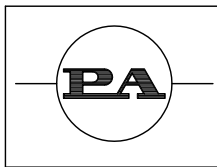

EQUIPAGGIAMENTI
TECNICI
LAVAGGIO

TESTINE ROTANTI
MOD. M25E ASPIRANTE



4 16

12.9416.00

20/12/05

M25E

25.4363.00 (I)-220Vca

25.4363.25 (I)-24Vca

25.4363.60 (USA)-110Vca

25.4363.24 (AUS)-240Vca

MANUALE D'ISTRUZIONE
GENERAL INTRUCTION BOOK

VERSIONE SPECIALE ACCORCIATA CON TERMINALE FLESSIBILE
SPECIAL SHORT VERSION WITH FLEXIBLE TERMINAL



TESTINA ELETTRICA PULIZIA
CONTENITORI E BOTTI.
ASPIRAZIONE INTERNA INTEGRATA.

- Testina per il lavaggio di contenitori e botti con sistema di aspirazione e scarico esterno del liquido utilizzato per il lavaggio.
- Portata ridotta, alta pressione, elevata forza di impatto.
- Copertura orbitale completa degli interni.
- Minimo ingombro radiale che ne permette l'introduzione attraverso passaggi ridotti.
- Alimentazione elettrica a bassa tensione.
- Costruzione in acciaio inox.
- Idonea per impiego settore alimentare.

ATTENZIONE !

- La Testina STANDARD è fornita di guarnizioni (DINAMICHE) in PTFE + O-Ring EPDM.
- Lubrificare esclusivamente con GRASSO SILICONICO codice: 14.6552.00
- Per l'utilizzo di liquidi detergenti, additivi chimici ecc. non compatibili con le guarnizioni standard è indispensabile contattare il nostro UFFICIO TECNICO.
- A richiesta le guarnizioni (DINAMICHE) O-RING sono disponibili anche in diverso materiale, NBR-FFKM(kalrez)-FKM(viton).
- Le guarnizioni (STATICHE) sono in FKM (viton).

ELECTRICAL HEAD DESIGNED TO
CLEAN SMALL TANKS AND BARRELS,
EQUIPPED WITH SUCTION SYSTEM.

- Tank cleaning head ideal for cleaning all types of tanks and barrels. It washes and, at the same time, siphons off the water used during the cleaning process.
- Reduced flow, high pressure, high cleaning impact.
- Complete orbital coverage of all interior surfaces.
- Reduced spray turret that fits through small barrel and tank openings.
- Low tension electric power.
- Stainless steel construction.
- Suitable for utilization in food industry.

ATTENTION !

- The STANDARD Tank cleaning head is supplied with seals (DYNAMIC) in PTFE + O-Ring EPDM.
- Lubricate ONLY with SILICONE GREASE P/N: 14.6552.00
- For use with Detergent liquid, Chemical additives etc that are not compatible with the standard seals, it is essential to contact our TECHNICAL OFFICE for further information.
- On request, the O-RING seals (DYNAMIC) are available in different materials such as NBR-FFKM(kalrez)-FKM(viton).
- The STATIC seals are in FKM (viton).

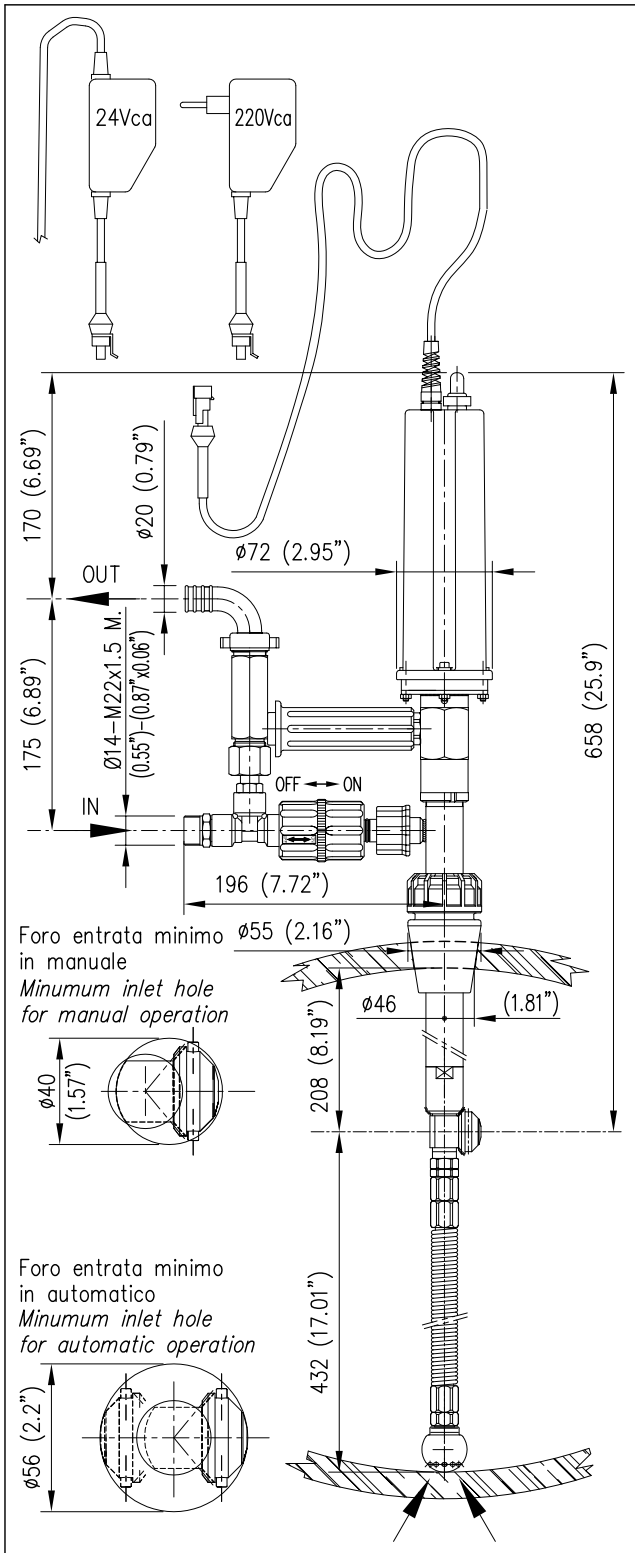

	A	B max.
-Testina speciale	Ø46	Ø680

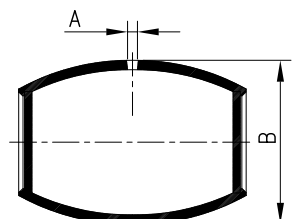

ATTENZIONE: NON UTILIZZARE
L'APPARECCHIO PRIMA DI AVER LETTO
QUESTO MANUALE DI ISTRUZIONE

CAUTION: DO NOT USE THE
CLEANING HEAD BEFORE HAVING READ
THE INSTRUCTION BOOK

CARATTERISTICHE TECNICHE TECHNICAL SPECIFICATIONS

M25E



20/12/05

- PRESSIONE NOMINALE <i>RATED PRESSURE</i>	MIN 60 bar - 6 MPa (870 psi)	140 bar - 14 MPa (2000 psi)
- PRESSIONE CONSENTITA <i>PERMISSIBLE PRESSURE</i>		160 bar - 16 MPa (2300 psi)
- PORTATA MASSIMA <i>MAX FLOW RATE</i>	MIN 10 l/min (2,6 USGp.m.)	25 l/min (6,5 USGp.m.)
- FATTORE DI PORTATA UGELLO VENTURI (ASPIRAZIONE) <i>FLOW FACTOR OF THE VENTURI NOZZLE (SUCTION)</i>		F.P. 02
- TEMPERATURA MASSIMA ACQUA <i>MAX WORKING TEMPERATURE</i>		90 °C (195°F)
- PESO <i>WEIGHT</i>		5.2 Kg
- FREQUENZA ROTAZIONE ASSE PRINCIPALE <i>MAIN AXIS ROTATING SPEED</i>		14 RPM
- ATTACCO ALIMENTAZIONE ACQUA <i>INLET CONNECTION SIZE</i>		ø14-M22x1.5 M (A)
- ATTACCO SCARICO ACQUA (PORTAGOMMA) <i>WATER OUTLET FITTING (HOSE BARB)</i>		ø20
- ATTACCO UGELLI N°2 <i>NOZZLES CONNECTION N°2</i>		M4
- TEMPO PER UN CICLO COMPLETO DI LAVAGGIO <i>TIME FOR A COMPLETE CLEANING CYCLE</i>		3 min
- MOTORE ELETTRICO: <i>ELECTRIC MOTOR:</i>		12W - 12V.cc
- ALIMENTATORE: <i>POWER SUPPLY:</i>	25.4350.00/25.4355.00 - 230V-50Hz/12V.cc-1A	
	25.4350.25 - 24V-ca/12V.cc-1A	
	25.4350.60 - 110V-60Hz/12V.cc-0.8A	
- LUNGHEZZA CAVO ALIMENTAZIONE: <i>POWER CABLE LENGTH</i>	25.4350.24 - 240V-50Hz/12V.cc-1A	10 m
- TENUTE (N.B. USARE SOLO GRASSO AL SILICONE codice:14.6552.00) <i>SEALS (N.B. USE P/N: 14.6552.00 SILICONE GREASE ONLY)</i>		(EPDM+PTFE) (VITON)

CADUTA DI PRESSIONE IN FUNZIONE DELLA PORTATA

LOSS OF PRESSURE IN RELATION TO FLOW

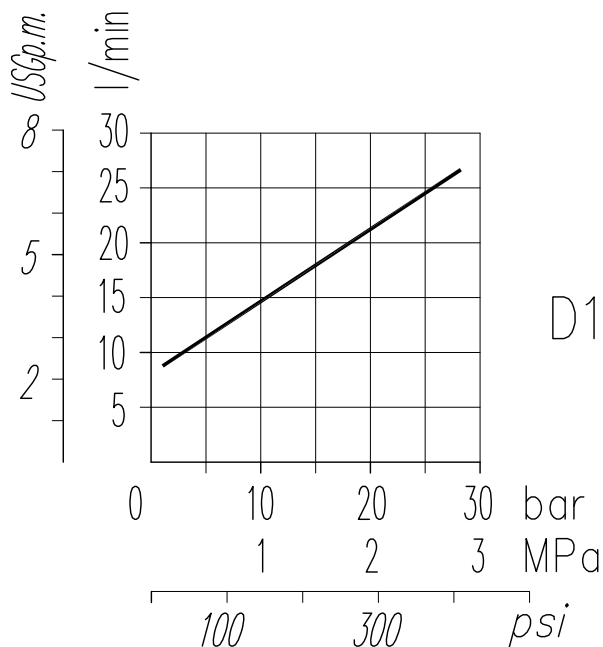

D2

UGELLI - NOZZLES

	codice	D(mm)	l/min(100bar)	F.P.
*	80.0350.51	1.00	4.6	02
	25.1191.51	1.05	5	023
*	80.0351.51	1.10	5.6	025
	25.1192.51	1.15	6.1	027
*	80.0352.51	1.20	6.7	03
	25.1193.51	1.25	7.1	032
*	80.0353.51	1.30	7.8	035
	25.1098.51	1.35	8.4	037
*	80.0354.51	1.40	9.1	04
	25.1194.51	1.45	9.7	043
	25.1095.51	1.50	10.3	045
	25.1195.51	1.55	11.2	05
	25.1196.51	1.60	12	053
	25.1197.51	1.62	12.6	055
	25.1186.51	1.66	13.7	06
	25.1198.51	1.72	14.8	065
	25.1199.51	1.8	16	07
	25.1085.51	2.00	18.2	08

* Ugelli forniti di serie (tipo corto)

* Standard nozzles supplied (short type) 12-2

CARACTERISTICAS TECNICAS

CARACTERISTIQUES TECHNIQUES

M25E



20/12/05

- PRESION NOMINAL <i>PRESION ASSIGNÉE</i>	MIN 60 bar - 6 MPa (870 psi)	140 bar - 14 MPa (2000 psi)
- PRESION CONSENTIDA <i>PRESION ADMISSIBLE</i>		160 bar - 16 MPa (2300 psi)
- CAUDAL MAXIMO <i>DÉBIT MAXI</i>	MIN 10 l/min (2,6 USGp.m.)	25 l/min (6,5 USGp.m.)
- FACTOR DE CAUDAL BOQUILLA VENTURI (ASPIRACION) <i>MESURE DE LA BUSE D'ASPIRATION</i>		F.P. 02
- TEMPERATURA MAXIMA AGUA <i>TEMPÉRATURE MAXI EAU</i>		90 °C (195°F)
- PESO <i>POIDS</i>		5.2 Kg
- FRECUENCIA ROTACION CAÑA PRINCIPAL <i>VITESSE DE ROTATION SUR L'AXE PRINCIPAL</i>		14 RPM
- ENCHUFE ALIMENTACION AGUA <i>CONNECTION ALIMENTATION EAU</i>		∅14-M22x1.5 M (A)
- ENCHUFE DESCARGA AGUA (PORTAGOMA) <i>CONNECTION DÉCHARGEMENT EAU (TIGE)</i>		∅20
- JUNTA BOQUILLAS N° 2 <i>CONNECTION BUSES (N°2)</i>		M4
- TIEMPO DE UN CICLO COMPLETO DE LAVADO <i>TEMPS POUR UN CYCLE COMPLET DE NETTOYAGE</i>		3 min
- MOTOR ELECTRICO: <i>MOTEUR ÉLECTRIQUE:</i>		12W - 12V.cc
- ALIMENTACION: <i>ALIMENTATEUR:</i>	25.4350.00/25.4355.00	- 230V-50Hz/12V.cc-1A
	25.4350.25	- 24V-ca/12V.cc-1A
	25.4350.60	- 110V-60Hz/12V.cc-0.8A
- LONGITUD MANGUERA DE ALIMENTACION: <i>LONGUEUR CABLE ALIMENTATION:</i>	25.4350.24	- 240V-50Hz/12V.cc-1A
		10 m
- CAPACIDAD (EMPLEAR SOLO GRASO SILICONA código: 14.6552.00) <i>JOINTS (N.B. UTILISER SEULEMENT GRAS AU SILICONE référence: 14.6552.00)</i>		(EPDM+PTFE) (VITON)

CAIDA DE PRESION EN FUNCION DEL CAUDAL

CHUTE DE PRESSION PAR RAPPORT AU DÉBIT

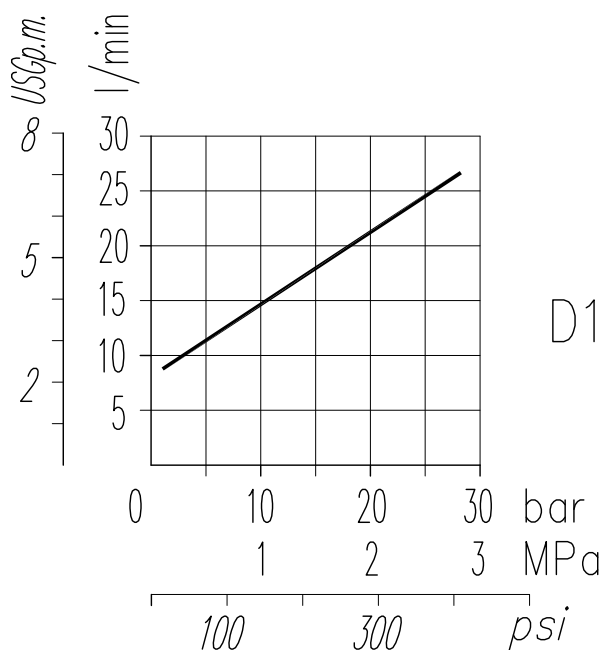

D2

BOQUILLAS - BUSES

	Código référence	D(mm)	l/min(100bar)	F.P.
*	80.0350.51	1.00	4.6	02
	25.1191.51	1.05	5	023
*	80.0351.51	1.10	5.6	025
	25.1192.51	1.15	6.1	027
*	80.0352.51	1.20	6.7	03
	25.1193.51	1.25	7.1	032
*	80.0353.51	1.30	7.8	035
	25.1098.51	1.35	8.4	037
*	80.0354.51	1.40	9.1	04
	25.1194.51	1.45	9.7	043
	25.1095.51	1.50	10.3	045
	25.1195.51	1.55	11.2	05
	25.1196.51	1.60	12	053
	25.1197.51	1.62	12.6	055
	25.1186.51	1.66	13.7	06
	25.1198.51	1.72	14.8	065
	25.1199.51	1.8	16	07
	25.1085.51	2.00	18.2	08

* Boquillas provistas de serie (tipo corto)

* Buses fournies de série (type court)

SCELTA INDICATIVA FATTORE DI PORTATA N°2 UGELLI
INDICATIVE CHOICE OF FLOW FACTOR N°2 NOZZLES

PRESSIONE bar – MPa – PRESSURE PSI

PORTATA POMPA l/min – PUMP FLOW GMP

25 6,5								160 16 2300	145 14,5 2100	135 13,5 1960	125 12,5 1810	110 11 1600	100 10 1450	95 9,5 1380	85 8,5 1230	70 7 1010	60 6 870
24 6,3							165 16,5 2400	150 15 2200	135 13,5 1960	125 12,5 1810	115 11,5 1670	100 10 1450	95 9,5 1380	90 9 1300	80 8 1150	65 6,5 940	
23 6,1							155 15,5 2250	140 14 2000	125 12,5 1810	115 11,5 1670	105 10,5 1560	95 9,5 1380	85 8,5 1230	80 8 1150	75 7,5 1080	60 6 870	
22 5,8						160 16 2300	140 14 2000	125 12,5 1810	115 11,5 1670	105 10,5 1520	100 10 1450	85 8,5 1230	80 8 1150	75 7,5 1080	70 7 1010		
21 5,5					155 15,5 2250	145 14,5 2100	125 12,5 1810	115 11,5 1670	105 10,5 1560	95 9,5 1380	90 9 1300	80 8 1150	75 7,5 1080	70 7 1010	65 6,5 940		
20 5,3			160 16 2300	140 14 2000	130 13 1900	115 11,5 1670	105 10,5 1560	95 9,5 1380	85 8,5 1230	80 8 1150	75 7,5 1080	65 6,5 940	60 6 870				
19 5		160 16 2300	145 14,5 2100	130 13 1900	120 12 1750	105 10,5 1520	95 9,5 1380	85 8,5 1230	80 8 1150	75 7,5 1080	65 6,5 940	60 6 870					
18 4,8	165 16,5 2400	145 14,5 2100	130 13 1900	115 11,5 1670	105 10,5 1520	95 9,5 1380	85 8,5 1230	80 8 1150	70 7 1010	65 6,5 940	60 6 870						
17 4,5	165 16,5 2400	150 15 2200	130 13 1900	115 11,5 1670	100 10 1450	95 9,5 1380	85 8,5 1230	75 7,5 1080	70 7 1010	65 6,5 940							
16 4,2	145 14,5 2100	130 13 1900	115 11,5 1670	100 10 1450	90 9 1300	85 8,5 1230	75 7,5 1080	70 7 1010	60 6 870								
15 4	130 13 1900	115 11,5 1670	100 10 1450	90 9 1300	80 8 1150	75 7,5 1080	65 6,5 940	60 6 870									
14 3,7	110 11 1600	100 10 1450	90 9 1300	80 8 1150	70 7 1010	65 6,5 940											
13 3,4	95 9,5 1380	85 8,5 1230	75 7,5 1080	65 6,5 940	60 6 870												
12 3,2	80 8 1150	75 7,5 1080	60 6 870														
11 2,9	70 7 1010	60 6 870															

FATTORE PORTATA N°1 UGELLO FLOW FACTOR N°1 NOZZLE	*		*		*		*		*								
	02	023	025	027	03	032	035	037	04	043	045	05	053	055	06	07	08
N° UGELLI DA MONTARE N° OF NOZZLES TO BE FITTED	2	2	2	2	2	2	2	2	2	2	2	2	2	2	2	2	2

* UGELLI DISPONIBILI TIPO CORTO
* NOZZLES AVAILABLE SHORT TYPE

N.B. E' OBBLIGATORIO MONTARE N°2 UGELLI AVENTI LO STESSO FATTORE DI PORTATA
N.B. IT IS MANDATORY TO FIT 2 NOZZLES HAVING THE SAME FLOW FACTOR

ELECCION INDICATIVA DEL FACTOR DE CAUDAL NR. 2 BOQUILLAS
CHOIX INDICATIF DIMENSIONS BUSES (N° 2 BUSES)

PRESION bar – MPa – PRESSION bar

CAUDAL BOMBA l/m – DÉBIT POMPE l/min

25 6,5								160 16 2300	145 14,5 2100	135 13,5 1960	125 12,5 1810	110 11 1600	100 10 1450	95 9,5 1380	85 8,5 1230	70 7 1010	60 6 870
24 6,3							165 16,5 2400	150 15 2200	135 13,5 1960	125 12,5 1810	115 11,5 1670	100 10 1450	95 9,5 1380	90 9 1300	80 8 1150	65 6,5 940	
23 6,1							155 15,5 2250	140 14 2000	125 12,5 1810	115 11,5 1670	105 10,5 1560	95 9,5 1380	85 8,5 1230	80 8 1150	75 7,5 1080	60 6 870	
22 5,8						160 16 2300	140 14 2000	125 12,5 1810	115 11,5 1670	105 10,5 1520	100 10 1450	85 8,5 1230	80 8 1150	75 7,5 1080	70 7 1010		
21 5,5					155 15,5 2250	145 14,5 2100	125 12,5 1810	115 11,5 1670	105 10,5 1560	95 9,5 1380	90 9 1300	80 8 1150	75 7,5 1080	70 7 1010	65 6,5 940		
20 5,3			160 16 2300	140 14 2000	130 13 1900	115 11,5 1670	105 10,5 1560	95 9,5 1380	85 8,5 1230	80 8 1150	75 7,5 1080	65 6,5 940	60 6 870				
19 5		160 16 2300	145 14,5 2100	130 13 1900	120 12 1750	105 10,5 1520	95 9,5 1380	85 8,5 1230	80 8 1150	75 7,5 1080	65 6,5 940	60 6 870					
18 4,8	165 16,5 2400	145 14,5 2100	130 13 1900	115 11,5 1670	105 10,5 1520	95 9,5 1380	85 8,5 1230	80 8 1150	70 7 1010	65 6,5 940	60 6 870						
17 4,5	165 16,5 2400	150 15 2200	130 13 1900	115 11,5 1670	100 10 1450	95 9,5 1380	85 8,5 1230	75 7,5 1080	70 7 1010	65 6,5 940							
16 4,2	145 14,5 2100	130 13 1900	115 11,5 1670	100 10 1450	90 9 1300	85 8,5 1230	75 7,5 1080	70 7 1010	60 6 870								
15 4	130 13 1900	115 11,5 1670	100 10 1450	90 9 1300	80 8 1150	75 7,5 1080	65 6,5 940	60 6 870									
14 3,7	110 11 1600	100 10 1450	90 9 1300	80 8 1150	70 7 1010	65 6,5 940											
13 3,4	95 9,5 1380	85 8,5 1230	75 7,5 1080	65 6,5 940	60 6 870												
12 3,2	80 8 1150	75 7,5 1080	60 6 870														
11 2,9	70 7 1010	60 6 870															

FACTOR CAUDAL NR. 1 BOQUILLA	*		*		*		*		*								
DIMENSION BUSE N° 1 BUSE	02	023	025	027	03	032	035	037	04	043	045	05	053	055	06	07	08
NR. BOQUILLA A MONTAR N° BUSES A INSTALLER	2	2	2	2	2	2	2	2	2	2	2	2	2	2	2	2	2

* BOQUILLAS DISPONIBLES TIPO CORTO

* BUSES TYPE COURT DISPONIBLES

N.B. ES OBLIGATORIO MONTAR NR. 2 BOQUILLAS CON EL MISMO FACTOR DE CAUDAL

N.B. IL FAUT MONTER N° 2 BUSES DE DIMENSIONS ÉGALES

ATTENZIONE !

La TESTINA viene messa in rotazione dal gruppo Moto riduttore elettrico posto all'estremità superiore che conferisce una coppia elevata in uscita, evitare eventuali bloccaggi della rotazione da parte di corpi estranei.

UTILIZZO

La TESTINA è costruita per funzionare con acqua fino a 90°C, additivata con detersivi o disinfettanti di uso generico. In caso di utilizzo con liquidi particolari (diversa viscosità, forte aggressività chimica o altro) consultare il nostro Ufficio Tecnico.

Utilizzare la TESTINA sempre entro i limiti di Pressione, Temperatura, Tensione previsti nelle CARATTERISTICHE TECNICHE di questo manuale.

INSTALLAZIONE

Al fine di prevenire possibili danni alle persone ed alle cose, la TESTINA deve essere collegata ad un circuito di Pressione, in genere alimentato da Pompe a pistoni, Idropultrici e simili, dotato di tutti gli organi di sicurezza e controllo (come Valvole di regolazione, di sicurezza etc.), previsti dalle normative vigenti per tali apparecchi. Per il collegamento utilizzare un tubo flessibile di adeguata sezione e resistenza, evitando il più possibile strozzature e brusche variazioni di direzione per contenere le cadute di pressione.

La TESTINA deve essere ancorata saldamente all'imboccatura del serbatoio o ad apposito sostegno, gli ugelli si devono trovare possibilmente al centro del serbatoio ed equidistanti dalle pareti.

SCELTA DEGLI UGELLI

Gli Ugelli (in numero di due) del tipo da lavaggio in alta pressione con getto rettilineo, dovranno essere adeguati alla Portata ed alla Pressione alle quali si intende operare (vedi D2), tenendo presente che il valore della Pressione da considerare nella scelta è quello che si ottiene sottraendo dal valore di Pressione nella pompa il valore della Caduta di Pressione determinata dalla linea di mandata e dalla TESTINA.

Quest'ultimo valore può essere ricavato dal diagramma D1 di questo manuale.

FUNZIONAMENTO

- 1) Collegare tubo alta pressione, collegare tubo raccolta scarico, collegare elettricamente.
- 2) Introdurre la testina nel recipiente da pulire (recipiente mancante di foro scarico).
- 3) Inserire il movimento di rotazione con apposito interruttore (lampadina accesa).
- 4) Aprire mandata acqua alta pressione e attendere la fine lavaggio (3 minuti min.). N.B. Sincerarsi che la manopola sia posizionata in corrispondenza del lato (ON).
- 5) A lavaggio ultimato rimarrà sul fondo del recipiente un certo quantitativo di acqua causato dall'impatto del getto ad alta pressione, per asportare anche questa quantità di acqua intervenire tramite la manopola, spostandola in corrispondenza del lato (OFF), questa manovra chiude il flusso dell'acqua agli ugelli ma permette comunque il funzionamento dell'aspirazione, operazione necessaria per lo svuotamento totale.

Prima di estrarre la testina dal contenitore sincerarsi che la mandata dell'acqua sia chiusa e che la lampadina indicatrice della rotazione testina sia spenta.

N.B. TARARE LA VALVOLA DI MASSIMA ALLA PRESSIONE DI FUNZIONAMENTO DESIDERATA PRIMA DEL FUNZIONAMENTO TESTINA SINCERANDOSI CHE ESISTA UN BY PASS DI ALMENO IL 5% DELLA PORTATA MASSIMA.

FILTRAGGIO

Il liquido inviato dal sistema alla testina va filtrato per impedire a corpi estranei di entrare , causa un cattivo funzionamento e di conseguenza interventi di manutenzione più frequenti, il grado di filtraggio consigliato è almeno **300 micron**.

MANUTENZIONE

Giornalmente dopo l'utilizzo normale eseguire un lavaggio interno della testina alimentandola con acqua pulita senza additivi.

Eseguire un controllo interno dopo 100 ore di lavoro per verificare le condizioni dei particolari interni (ingranaggi, cuscinetti, guarnizioni dinamiche). La scelta errata del materiale dell'OR (guarnizioni dinamiche), causa un funzionamento anomalo e un rapido deterioramento di questi particolari, in presenza di alterazioni dimensionali (**Rigonfiamento**) delle guarnizioni dinamiche (OR+PTFE).

Controllare la compatibilità dell'OR con i liquidi utilizzati, qualora non siano compatibili, contattare il nostro UFFICIO TECNICO.

Eseguire un controllo interno ogni 300÷400 ore di lavoro, per verificare l'eventuale usura dei particolari interni. Si consiglia la sostituzione delle guarnizioni dinamiche (pos.10 pos.12) verificando preventivamente che le superfici di scorrimento siano in buono stato; se usurate **sostituire**.

Verificare inoltre le condizioni dei cuscinetti, delle boccole e degli ingranaggi ; **se danneggiati sostituire**.

Utilizzare esclusivamente ricambi originali 'PA'.

Nelle zone e nei periodi dell'anno a rischio di gelo accertarsi, a fine lavoro, del completo svuotamento della TESTINA .

Lubrificare **solo** con grasso **SILICONICO codice: 14.6552.00** , **NON UTILIZZARE GRASSO O OLIO A BASE MINERALE, PENA LA ROTTURA DEGLI ORGANI INTERNI.**

AVVERTENZE SULLA SICUREZZA

- I getti di alta pressione possono essere pericolosi se soggetti ad uso non corretto. Il getto non deve essere diretto verso persone o apparecchiature elettriche sotto tensione.

- Accertarsi che l'impianto di pompaggio sia dotato di una Valvola di sicurezza idonea alle prestazioni richieste.

- Per garantire la sicurezza dell'apparecchio usare solamente parti di ricambio originali PA o da essa approvati.

- Condotti per alta pressione, giunti e collegamenti sono importanti ai fini della sicurezza dell'apparecchio.

Usate solo condotti, giunti e collegamenti correttamente dimensionati e garantiti dal costruttore.

- METTERE IN FUNZIONE LA TESTINA SOLO DOPO AVERLA INSERITA E BLOCCATA AL SERBATOIO.

- TOGLIERE LA TESTINA DAL SERBATOIO SOLO DOPO AVERE DISINSERITA LA ROTAZIONE E L'ALIMENTAZIONE DEL LIQUIDO DI LAVAGGIO.

- CON L'UTILIZZO DI LIQUIDO DI LAVAGGIO CALDO NON TOCCARE LE PARTI METALLICHE.

NORMATIVA

Le Testine oggetto del presente manuale hanno la marcatura CE, in quanto rispondenti alla Direttiva EMC 89/336 CEE, 92/31 CEE, 93/68 CEE ed alle norme applicate EN 55014, EN 55104, EN 61000-3-2, EN 61000-3-3.

ATTENTION !

The cleaning head is placed in rotation by an electric gear motor set positioned on the upper point that gives a high torque on exit. Avoid possible jamming of the rotation from excess material.

UTILIZATION

This cleaning head is designed to be used with water up to 90° C - 194°F, mixed with detergents or disinfectants of general use. Before using specific liquids (high viscosity, very aggressive chemicals or else) consult our technical department. Make sure the equipment is always used within the limits (Pressure, Temperature, Voltage) as specified in this manual.

INSTALLATION PROCEDURE

In order to avoid bodily injuries and damages to property, the cleaning head must always be connected to a pressure circuit, normally fed by a piston pump, pressure washer or similar equipment, provided with all necessary safety and control features (safety valve, pressure regulator etc..) requested by law for such appliances. For the connection make sure that a flexible hose with correct capacity and resistance is used, avoiding sharp bends and variation of flow direction in order to reduce pressure drop. The head must be firmly secured to the tank opening or a suitable support and the nozzles must preferably be in the centre of the tank and equidistant from the tank walls.

CHOICE OF NOZZLES

The two solid stream spray nozzles for high pressure washing must be adequate to operating flow rate and pressure (see D2), bearing in mind that the pressure value to be taken into consideration while choosing, is the one obtained by subtracting from the pump pressure the loss of pressure determined by the delivery line and the head itself, the latter value can be obtained from diagram D1 in this manual.

WORKING

- 1) Connect the high pressure tube, the discharge tube and the electrical plug.
- 2) Insert the head inside the tank (tank without discharge hole).
- 3) Switch on the head (light on).
- 4) Open the high pressure delivery line and wait until the washing cycle ends (min. 3 minutes). **REMARK:** Please check that the handle has been set in correspondence of the (ON) side.
- 5) At the end of the washing cycle you will notice that some water remains on the tank bottom : turn the handle towards the (OFF)side. This operation closes the water flow to the nozzles, but permits the complete suction of the water out of the tank bottom. This operation is necessary to empty the tank.

Before taking the head out of the tank, please check that the delivery line is closed and that the light (rotation indicator) is off.

N.B.: ADJUST THE VALVE AT THE REQUIRED WORKING PRESSURE BEFORE STARTING THE HEAD AND CHECK THAT 5% OF THE MAXIMUM FLOW RATE FLOWS OUT IN BY-PASS.

FILTRATION

The fluid sent from the system to the cleaning head has to be filtered in order to prevent the entrance of any body matter due to bad functioning which leads to frequent maintenance.

The degree of filtration recommended is at least **300 micron**.

SERVICING

After a normal daily usage, wash the internal part of the head only with water minus any additives.

After 100 hours of labour, check the conditions of the internal parts (gears, dynamic seals).

The incorrect choice of the O-Ring material (dynamic seals) can cause an irregular function and a rapid deterioration of these parts.

In presence of dimensional alterations (**swelling**) of the dynamic seals (OR+PTFE) , control the compatibility of the O-Rings with the liquids used.

If they result non-compatible, contact our TECHNICAL OFFICE.

Check the internal parts every 300÷400 hours of labour in order to verify any premature wear, especially the dynamic seals (pos.10 & 12), verify precautionally also the surface way if still in good shape, **otherwise replace if worn**.

Check also the conditions of the bearing, bushings, gears, **replace if damaged**.

Use only original 'PA' spare parts.

If exposed to freezing temperatures make sure that the head is completely emptied after use in order to prevent freeze up.

Lubricate with P/N: **14.6552.00 SILICONE** grease only, **DO NOT USE MINERAL GREASE OR OIL, OTHERWISE RUPTURE OF THE INTERNAL PARTS MAY OCCUR.**

SAFETY INFORMATION

- **Improper use of high pressure jets can be very dangerous**
- **Never point the jets towards people or electrical appliances**
- **Make sure that the pumping system is equipped with suitable safety devices**
- **Original PA parts only must be used for repair and servicing**
- **High pressure pipes and connections are very important to the general safety of the equipment. Be sure to use only components correctly sized and guaranteed by the manufacturer.**

- | |
|---|
| <ul style="list-style-type: none">• OPERATE THE HEAD ONLY AFTER IT HAS BEEN PLACED INTO THE TANK AND FIRMLY SECURED.• TAKE THE HEAD OUT OF THE TANK ONLY AFTER ROTATION AND WASHING WATER FEEDING HAVE BEEN STOPPED.• DO NOT TOUCH METAL PARTS WHEN USING HOT WASHING WATER. |
|---|

STANDARDS

The cleaning heads described herein have the CEE marking as per the DIRECTIVE EMC89/366 CEE, 93/68 CEE and the standard specifications EN55014, EN61000-3-2, EN55104

ATENCIÓN!

El cabezal de lavado se pone en rotación por medio del grupo Motoreductor eléctrico puesto a la extremidad superior, conferendo una pareja elevada en salida, evitando eventuales bloqueos de la rotación por medio de cuerpos ajenos.

UTILIZACIÓN

El cabezal ha sido construido para el funcionamiento con agua hasta 90°C, y detergentes o desinfectantes de utilización genérica. En caso de utilización con detergentes particulares (diferente viscosidad, fuerte agresividad química o bien otro) consultar nuestra oficina técnica. Utilizar el cabezal siempre dentro de los límites de Presión, Temperatura, Tensión previstos en las características técnicas de este manual.

INSTALACIÓN

Para prevenir posibles daños a las personas o a las cosas, el cabezal tiene que ser conectado a un circuito de Presión, en general alimentado por bombas a pistones, hidrolimpiadoras y similar, equipado con todos los órganos de seguridad y control (como válvulas de regulación, de seguridad etc.) previstos por la legislación actual en referencia a tales aparatos. Para la conexión emplear una manguera flexible de sección y resistencia adecuada, evitando lo más posible codos y brascas variaciones de dirección para contener las caídas de presión. El cabezal tiene que ser establemente fijado a la embocadura del depósito o bien a un adecuado soporte, las boquillas posiblemente tienen que encontrarse en el centro del depósito y equidistantes de las paredes.

ELECCIÓN DE LAS BOQUILLAS

Las boquillas con chorro recto de alta presión (en cantidad de dos), tendrán que ser adecuadas al caudal y a la presión dentro de las cuales se quiere operar (ver D2). La presión de las boquillas se obtiene sustrayendo del valor de presión de la bomba el valor de caída de presión determinada por la línea de retorno y por el cabezal.

Este último valor puede ser obtenido del diagrama D1 de este manual.

FUNCIONAMIENTO

- 1) Conectar manguera alta presión, conectar manguera retorno, conectar eléctricamente.
- 2) Introducir el cabezal en el envase de limpiar (envase que falta de agujero de descarga).
- 3) Introducir el movimiento de rotación con adecuado interruptor (bombilla encendida).
- 4) Abrir grifo de agua alta presión y esperar el fin del lavado (3 minutos min.). Averiguar que la manopla sea posicionada en correspondencia del lado (ON).
- 5) Al lavado ultimado quedará sobre el fondo del envase una cantidad de agua; para llevar también esta cantidad de agua intervenir con la manopla desplazándola en correspondencia del lado (OFF). Tal maniobra cierra el flujo de agua a las boquillas pero de toda manera permite el funcionamiento de la aspiración, operación necesaria para el vaciado total. Antes de sacar el cabezal del envase, averiguar que el grifo de agua sea cerrada y que la bombilla (indicativa de la rotación) sea apagada.

N.B. REGULAR LA VALVULA A LA PRESION DE FUNCIONAMIENTO DESEADA ANTES DEL FUNCIONAMIENTO CABEZAL AVERIGUANDO QUE POR LO MENOS EL 5% DEL CAUDAL MAXIMO SEA DESCARGADO EN BY-PASS.

FILTRAJE

El líquido enviado por el sistema al cabezal de lavado há de ser filtrado para impedir la penetración de cuerpos estrangeros que causarían un malo funcionamiento y de consecuencia las intervenciones de manutención más frecuentes. El grado de filtraje recomendado es de **300 micron** al menos.

MANUTENCIÓN

Cada día despues la utilización normal efectuar un lavado interno del cabezal alimentandolo con agua limpia sin aditivos. Efectuar un control interno despues 100 horas de trabajo para verificar las condiciones de los componentes internos (engranajes, cojinetes, guarniciones dinámicas). La elección incorrecta del material del anillo tórico (guarniciones dinámicas) causa un funcionamiento anormal y un rápido deterioro de estos componentes en presencia de alteraciones dimensionales (**Hinchamiento**) de las guarniciones dinámicas (anillos tóricos + PTFE). Controlar la compatibilidad del anillo tórico con los líquidos utilizados; en caso de que no fueran compatibles, contactar nuestra OFICINA TÉCNICA.

Efectuar un control interno cada 300-400 horas de trabajo para verificar la eventual usura de los componentes internos. Se recomienda la sustitución de las guarniciones dinámicas (pos. 10 pos. 12) verificando preventivamente que las superficies de deslizamiento sean en buenas condiciones; si están usuradas, **sustituirlas**.

Verificar también las condiciones de los cojinetes, de los casquillos y de los engranajes; **si están dañados, sustituirlos**.

Utilizar exclusivamente repuestos originales 'PA'.

En las zonas y los períodos del año a riesgo de hielo, en la fin del trabajo cerciorarse del drenaje completo del CABEZAL DE LAVADO. Lubrificar solamente con **GRASA SILICÓNICA código: 14.6552.00**, **NO UTILIZAR GRASA O ACEITE A BASE MINÉRAL, PARA NO CAUSAR LA ROTURA DE LOS ÓRGANOS INTERNOS.**

ADVERTENCIAS SOBRE LA SEGURIDAD

-Los chorros de alta presión pueden ser peligrosos sometidos a empleo no correcto. No dirigir el chorro en dirección de personas o de aparatos eléctricos bajo tensión.

-Averiguar que la instalación de bombas sea dotada de una válvula de seguridad idónea a las prestaciones. necesarias

-Para garantizar la seguridad del aparato emplear solamente partes de recambio originales P.A. o de la misma aprobadas

-Mangueras de alta presión, juntas y conexiones son importantes para la seguridad del aparato. Emplear solo mangueras, juntas y conexiones de correcta dimensión y garantizados por el productor.

- | |
|---|
| <ul style="list-style-type: none">- PONER EN FUNCIONAMIENTO EL CABEZAL SOLO DESPUES LA INSERCIÓN Y EL BLOQUEO DEL MISMO AL DEPOSITO.- SACAR EL CABEZAL DEL DEPOSITO SOLO DESPUES DE LA PARADA DE LA ROTACIÓN Y LA ALIMENTACIÓN DEL LÍQUIDO DE LAVADO.- EMPLEANDO LÍQUIDO DE LAVADO CALIENTE NO TOCAR LAS PARTES METÁLICAS. |
|---|

NORMA

Los cabezales en objeto en el presente manual tienen el control CE, dado que responden a la directiva EMC 89/336 CEE, 92/31 CEE, 93/68 CEE y a la normas aplicadas EN 55014, EN 61000-3-2, EN 61000-3-3.

ATTENTION !

La TÊTE DE LAVAGE se met en rotation au moyen du groupe Moto-réducteur électrique qui se trouve à l'extrémité supérieure et conférant un couple élevé en sortie, tout en évitant d'éventuels arrêts de la rotation par des corps étrangers.

UTILISATION

La TÊTE est fabriquée pour travailler avec eau à une température maxi de 90°C et on peut rajouter produits chimiques ou désinfectants d'utilisation générale. En cas d'utilisation avec liquides particuliers (viscosité différente, agressivité chimique élevée ou autre) consulter notre Service Technique. Utiliser toujours la TÊTE dans les limites de Pression, Température, Tension mentionnées dans les CARACTÉRISTIQUES TECHNIQUES de ce manuel.

INSTALLATION

Afin de prévenir dommages possibles aux personnes et aux choses, la TÊTE doit être installée sur un circuit à haute pression, normalement alimenté par une Pompe à pistons, Nettoyeurs et similaires, avec tous les éléments de sécurité et contrôle nécessaires (comme Vannes de Réglage Pression, Vannes de sécurité, etc.) prévus par les Normes en vigueur pour ces appareils.

Pour la connexion utiliser un tuyau flexible de diamètre et résistance appropriés, évitant le plus que possible étranglements ou brusques variations de direction pour limiter les chutes de pression. La TÊTE doit être bien fixée au trou du réservoir ou bien placée par un support adéquat, les buses doivent se trouver possiblement au centre du réservoir à nettoyer, à la même distance des parois.

CHOIX DES BUSES

Les buses (en numéro de deux) du type pour nettoyage à haute pression avec jet droit, doivent être de dimensions adéquates par rapport au Débit et à la Pression d'utilisation (voir D2), faisant attention au fait que la valeur de la Pression qu'il faut considérer pour ce choix, est la valeur obtenue de la soustraction de la Pression dans la pompe et la Chute de Pression déterminée par la section entre le by-pass et la TÊTE. Pour la calcul de cette valeur voir schéma D1 de ce manuel.

FONCTIONNEMENT

- 1) Installer le tube à haute pression, le tube de déchargement, faire la connexion électrique.
- 2) Positionner la tête à l'intérieur du réservoir à nettoyer (réservoir sans trou de déchargement).
- 3) Démarrer la tête au moyen de l'interrupteur aménagé exprès (voyant allumé).
- 4) Faire passer l'eau en haute pression et attendre la fin du cycle de lavage (3 min. minimum).
REMARQUE : Assurez-vous que le bouton soit positionné en correspondance du côté (ON)
- 5) Quand le nettoyage sera terminé, sur le fond du réservoir il y aura une certaine quantité d'eau résiduelle du cycle de nettoyage à haute pression. Pour emporter aussi cette quantité résiduelle il faut tourner le bouton en le déplaçant en correspondance du côté (OFF). Cette manœuvre arrête le passage de l'eau aux buses mais permet d'aspirer le liquide, opération nécessaire pour vider entièrement le réservoir.
Avant de tirer la tête du réservoir, assurez-vous que l'alimentation de l'eau soit fermée et que le voyant lumineux (indicateur du fonctionnement de la tête) soit éteint.

N.B. ÉTALONNER LA VANNE À LA PRESSION D'UTILISATION SOUHAITÉE AVANT LA MISE EN FONCTION DE LA TÊTE ET S'ASSURER QU'AU MOINS 5% DU DÉBIT MAXI SOIT DÉCHARGÉ EN BY-PASS.

FILTRAGE

Le liquide envoyé par le système à la tête de lavage doit être filtré pour empêcher la pénétration d'éventuels corps étrangers qui pourraient causer un mauvais fonctionnement et par conséquent des interventions d'entretien plus fréquents. Le degré de filtrage conseillé est de **300 micron** au moins.

ENTRETIEN

Chaque jour après l'usage normal effectuer un lavage interne de la tête de lavage en l'alimentant avec de l'eau propre sans additifs. Effectuer un contrôle interne après 100 heures de travail pour vérifier les conditions des composants internes (engrenages, roulements, joints dynamiques). Le choix faux du matériel du joint torique (joints dynamiques) cause un fonctionnement anormal et une détérioration de ces composants en présence d'altérations dimensionnelles (**Gonflement**) des joints dynamiques (joints toriques + PTFE). Contrôlez la compatibilité du joint torique avec les liquides utilisés ; au cas où ils n'étaient pas compatibles, contactez notre SERVICE TECHNIQUE. Effectuez un contrôle interne toutes les 300-400 heures de travail pour vérifier l'éventuelle usure des composants internes. Nous conseillons le remplacement des joints dynamiques (pos. 10 pos. 12) tout en vérifiant préalablement que les surfaces de glissement soient en bonnes conditions ; si elles sont usées, **remplacez-les**.

Vérifiez aussi les conditions des roulements, des douilles et des engrenages ; **s'ils sont endommagés, remplacez-les**.

Utilisez uniquement les pièces détachées originales 'PA'.

Dans les zones et les périodes de l'année à risque de gel, à la fin du travail assurez-vous du vidage complet de la TÊTE DE LAVAGE.

Lubrifiez uniquement avec de la **GRAISSE SILICONIQUE référence: 14.6552.00**, **N'UTILISEZ PAS DE GRAISSE OU HUILE A BASE MINÉRALE, OU VOUS CAUSEREZ LA RUPTURE DES ORGANES INTERNES.**

NOTES SUR LA SÉCURITÉ

- Les buses à haute pression peuvent être dangereuses si utilisées improprement. Le jet de l'eau ne doit pas être dirigé vers personnes ou appareils électriques sous tension.
 - S'assurer que la pompe soit équipée avec une vanne de sécurité adéquate aux performances souhaitées.
 - Pour garantir la sécurité de l'appareil utiliser seulement pièces de rechanges originales ou approuvées par P.A.
 - Tubes haute pression, connexions et raccords sont importants afin de la sécurité de l'appareil.
- Utiliser seulement tubes, connexions et raccords des dimensions adéquates et garantis par le fabricant.

- **METTRE EN FONCTION LA TÊTE SEULEMENT APRÈS L' AVOIR BIEN INSTALLÉE ET FIXÉE À L'INTÉRIEUR DU RÉSERVOIR À NETTOYER.**
- **ENLEVER LA TÊTE DU RÉSERVOIR SEULEMENT APRÈS AVOIR ARRÊTÉ LA ROTATION DES BUSES ET L'ALIMENTATION DE L'EAU.**
- **EN CAS DE NETTOYAGE AVEC EAU CHAUDE, ÉVITER DE TOUCHER LES PARTIES MÉTALLIQUES.**

NORMES

Les Têtes de ce manuel sont marquées CE, étant conformes aux Normes EMC 89/336 CEE, 92/31 CEE, 93/68 CEE et aux Normes appliquées EN 55014, EN 55104, EN 61000-3-2, EN 61000-3-3.

25.4350.00 M25E test.mot.el+aspir.220Vca/50Hz
25.4350.24 M25E test.mot.el+aspir.240Vca/50Hz AUS

25.4350.25 M25E test.mot.el+aspir.24Vca
25.4350.60 M25E test.mot.el+aspir.115Vca/60Hz USA

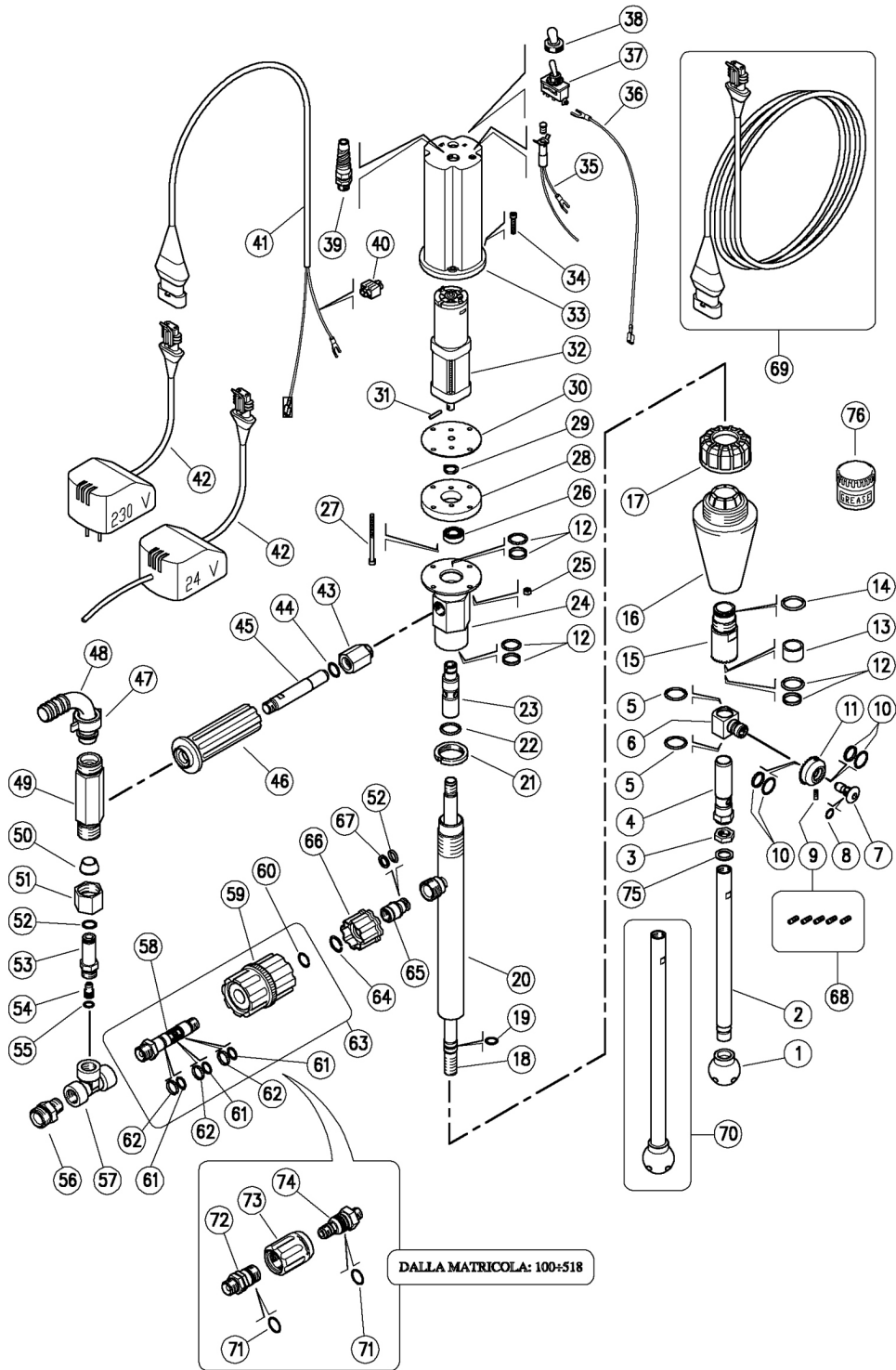

Pos.	Codice	Descrizione	Q.tà	K1	K2	K3	K4	Pos.	Codice	Descrizione	Q.tà	K1	K2	K3	K4	
1	80.0330.81	Respingente forato POM bianco	1				5	36	12.5019.25	Cavo 1x0,75 L.250 mm	1				5	
2	80.0329.56	Tube aspirante G1/4F 280mm inox	1				5	37	12.5016.10	Interr.unipol. on/off	1				3	
2	80.0388.56	Tube aspirante G1/4F 380mm inox (1)	1				5	38	12.5016.05	Protezione interruttore	1				5	
3	80.0328.51	Ghiera G1/4F inox	1				5	39	13.5997.00	Pressacavo 1/4 +protezione	1				5	
4	80.0327.51	Perno porta guarnizioni inox	1				5	40	12.5019.47	Rubacorrente	1				5	
5	10.3010.10	An.OR 1x18 mm Vi 70	2	•	•	•	10	41	12.5019.10	Cavo 2x1,5 mm 10m+connessione F	1				5	
6	80.0331.51	Statore inox	1				1	42	12.5071.00	Trasf. 230Vca/12Vcc EU (2)	1				1	
7	80.0325.51	Perno M10x1 inox	1				1	42	12.5071.24	Trasf. 240Vca/12Vcc AUS (3)	1				1	
8	10.3055.10	An.OR 1,78x7,66 mm Vi 70	1	•	•	•	10	42	12.5071.25	Trasf. 24Vca/12Vcc EU (4)	1				1	
9	15.3704.00	Tappo M4 plast.	2				4	42	12.5071.60	Trasf. 115Vca-60Hz/12Vcc USA (5)	1				1	
9	80.0350.51	Ugello 02 - 1,0mm - M4 inox verde ch.	2	•			10	43	80.0338.31	Racc. M16x1 M ott.+Ni	1				10	
9	80.0351.51	Ugello 025 - 1,1mm - M4 inox rosa	2	•			10	44	10.3179.10	An.OR 2,62x13,94 mm Vi 70	1	•	•	•	10	
9	80.0352.51	Ugello 03 - 1,2mm - M4 inox bianco	2	•			10	45	80.0337.56	Tube aspirazione G1/4M 113mm inox	1				3	
9	80.0353.51	Ugello 035 - 1,3mm - M4 inox marrone	2	•			10	46	80.0344.85	Manopola 32x110mm PP nera	1				5	
9	80.0354.51	Ugello 04 - 1,4mm - M4 inox giallo	2	•			10	47	80.0347.35	Girello G3/4 ott.+Ni	1				5	
10	10.2030.00	Guarn. stelo 15x20x2,2 mm +OR	2	•	•	•	4	48	80.0346.35	Gomito ptgm 20mm ott.+Ni	1				3	
11	80.0326.51	Pignone portaug. z.41 M4 FF inox	1				3	49	80.0336.31	Racc. venturi ott.+Ni	1				3	
12	10.2030.18	Guarn. stelo 18x23x2 mm +OR Epdm	3	•	•	•	5	50	80.0335.81	An.conico a. 14x20x11mm POM bianco	1				10	
13	80.0024.85	Boccola a. 18x22x14,8mm PTFE	1				5	51	80.0334.31	Ghiera M24x1,5 ott.+Ni	1				5	
14	10.3026.10	An.OR 1,5x20 mm Vi 70	1	•	•	•	10	52	10.3109.95	An.OR 2,4x9,3 mm Vi 70	2	•	•	•	25	
15	80.0372.23	Pignone z.34 inox+Boccola a.15mm PTFE	1				3	53	80.0333.31	Racc. porta ugello G3/8M ott.+Ni	1				3	
16	80.0021.84	Tappo conico TPEs nero	1				3	54	25.0019.51	Ugello 02 d.10,5x15 mm inox	1				5	
17	80.0316.84	Ghiera PP nera	1				10	55	10.3052.00	An.OR 1,78x6,75 mm	1	•	•	•	25	
18	80.0322.56	Tube G1/4 MM 600mm inox	1				3	56	80.0348.31	Racc. G3/8M-M22x1 M ott.+Ni	1				3	
18	80.0389.56	Tube G1/4 MM 500mm inox (1)	1				3	57	80.0349.35	Racc. a T G3/8 FFF ott.+Ni	1				3	
19	10.3007.10	An.OR 1x12 mm Vi 70	1	•	•	•	25	58	80.0402.31	Racc. distrib. G3/8M-G1/4M ott.	1				3	
20	80.0343.21	Tube + raccordo M22 inox	1				3	59	80.0403.21	Manopola PA nera + Inserto ott.	1				3	
20	80.0390.21	Tube spec. + raccordo M22 inox (1)	1				3	60	29.0402.51	An. elast. 1,6x14,3 mm inox	1				5	
21	80.0012.51	Ghiera M28x1 inox	1				1	61	10.3058.10	An.OR 1,78x10,82 mm Vi 70	3			•	10	
22	10.3205.10	An.OR 2,62x26,64 mm Vi 70	1	•	•	•	10	62	10.4058.00	An.tenuta 14x16x2 mm	3				•	10
23	80.0321.51	Albero di trasmissione inox	1				1	63	80.0400.00	Regolat. di portata RF1 G3/8M-G1/4M	1				3	
24	80.0341.21	Collettore inox	1				2	64	26.0252.51	An. elast. 1,5x15,5 mm inox	1				10	
25	11.4513.10	Dado es. M4 inox	4				10	65	26.0261.31	Spinotto 14mm-G1/4F ott.	1				10	
26	11.4412.28	Cuscinetto 12x28x8 mm - 2RS1 inox	1				3	66	26.0260.22	Girello M22x1,5 17,5mm nero	1				10	
27	16.1860.00	Vite DIN912 M4x60 mm inox	2				10	67	10.4010.01	An. anties. a. 10,2x13,9x1,2 mm	1	•	•	•	50	
28	80.0318.41	Flangia motore	1				3	68	25.4320.24	Kit Ugelli M4 - M21E 2x5pz.	1				1	
29	10.0999.05	An. elast. E 12 inox	1				10	69	25.4353.20	Prol. -M21E 20m 12Vcc MF **	1				1	
30	80.0317.88	Guarniz. per motore, NBR	1				2	70	80.0380.00	Tube aspirante per botte Ø940mm **	1				1	
31	15.1030.00	Spina elast. 3x16 mm inox	1				10	70	80.0386.00	Tube aspirante per botte Ø1070mm **	1				1	
32	13.0827.00	Motoriduttore 12V 10Rpm	1				1	71	10.3066.10	An.OR 1,78x15,6 mm Vi 70	2			•	10	
33	80.0301.84	Carter motore PA nero	1				1	75	14.3911.00	Rosetta 13,5x19x1,5 mm Cu	1				10	
34	16.1856.00	Vite DIN912 M4x25 mm inox	4				10	76	14.6552.00	Grasso silicone al teflon *30g. **	1				2	
35	12.5019.31	Lampada spia	1				5									

** Su richiesta

Kit	Codice	Descrizione	Q.tà
K1	25.4320.24	Kit Ugelli M4 - M21E 2x5pz.	1
K2	25.4356.24	Kit ric.guarn. M25E (mat.1-100) 13x1pz.	1
K3	25.4357.24	Kit ric.guarn.M25E (mat.101-518) 12x1pz	1
K4	25.4360.24	Kit ric.guarn. M25E (mat.519>) 13x1pz.	1

(1) 25.4355.00 (2) 25.4350.00 (3) 25.4350.24 (4) 25.4350.25 (5) 25.4350.60

25.4350.00 M25E Barrel cl.,elect.driv+suction
25.4350.24 M25E Barrel cl.,elect.driv+suction AUS

25.4350.25 M25E Barrel cl.,el.driv+suct.24V AC
25.4350.60 M25E Barrel cl.,+suct. 115V AC/60Hz USA

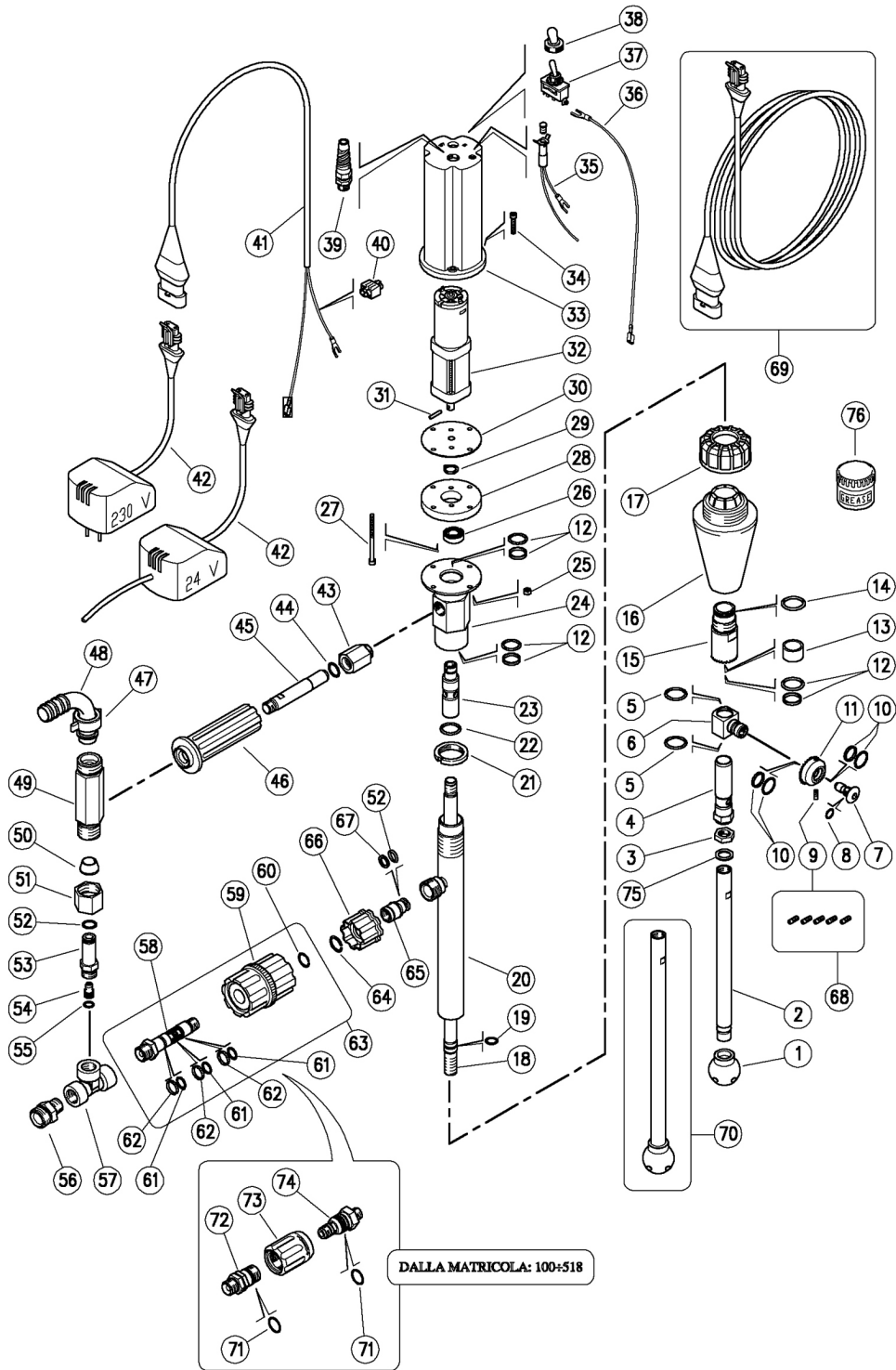

Pos.	P/N	Description	Q.ty	K1	K2	K3	K4	
1	80.0330.81	Pierced buffer, POM white	1					5
2	80.0329.56	Suction tube, 1/4F Bsp 280mm Sst.	1					5
2	80.0388.56	Suction tube, 1/4F Bsp 380mm Sst. (1)	1					5
3	80.0328.51	Ring nut, 1/4F Bsp Sst.	1					5
4	80.0327.51	Seal holding pin, Sst.	1					5
5	10.3010.10	O-ring, 1x18 mm Vi 70	2	•	•	•		10
6	80.0331.51	Stator, Sst.	1					1
7	80.0325.51	Pin, M10x1 Sst.	1					1
8	10.3055.10	O-ring, 1,78x7,66 mm Vi 70	1	•	•	•		10
9	15.3704.00	Plug, M4 plast.	2					4
9	80.0350.51	Nozzle, 02 - 1,0mm - M4 Sst. light green	2	•				10
9	80.0351.51	Nozzle, 025 - 1,1mm - M4 Sst. pink	2	•				10
9	80.0352.51	Nozzle, 03 - 1,2mm - M4 Sst. white	2	•				10
9	80.0353.51	Nozzle, 035 - 1,3mm - M4 Sst. brown	2	•				10
9	80.0354.51	Nozzle, 04 - 1,4mm - M4 Sst. yellow	2	•				10
10	10.2030.00	Stem seal, 15x20x2,2 mm +O-ring	2	•	•	•		4
11	80.0326.51	Nzl hold. pinion, z.41 M4 FF Sst.	1					3
12	10.2030.18	Stem seal, 18x23x2 mm +O-ring Epdm	3	•	•	•		5
13	80.0024.85	Bushing, opn. 18x22x14,8mm PTFE	1					5
14	10.3026.10	O-ring, 1,5x20 mm Vi 70	1	•	•	•		10
15	80.0372.23	Pinion, z.34 Sst.+bushing,opn.15mm PTFE	1					3
16	80.0021.84	Tapered plug, TPEs black	1					3
17	80.0316.84	Ring nut, PP black	1					10
18	80.0322.56	Tube, 1/4Bsp MM 600mm Sst.	1					3
18	80.0389.56	Tube, 1/4Bsp MM 500mm Sst. (1)	1					3
19	10.3007.10	O-ring, 1x12 mm Vi 70	1	•	•	•		25
20	80.0343.21	Tube + coupling, M22 Sst.	1					3
20	80.0390.21	Special tube + coupling, M22 Sst. (1)	1					3
21	80.0012.51	Ring nut, M28x1 Sst.	1					1
22	10.3205.10	O-ring, 2,62x26,64 mm Vi 70	1	•	•	•		10
23	80.0321.51	Propeller shaft, Sst.	1					1
24	80.0341.21	Manifold, Sst.	1					2
25	11.4513.10	Hex. nut, M4, Sst.	4					10
26	11.4412.28	Ball-bearing, 12x28x8 mm - 2RS1 Sst.	1					3
27	16.1860.00	Screw, DIN912 M4x60 mm Sst.	2					10
28	80.0318.41	Motor flange	1					3
29	10.0999.05	Snap ring, E 12 Sst.	1					10
30	80.0317.88	Motor seal, NBR	1					2
31	15.1030.00	Roll pin, 3x16 mm Sst.	1					10
32	13.0827.00	Gearmotor, 12V 10Rpm	1					1
33	80.0301.84	Motor casing, PA black	1					1
34	16.1856.00	Screw, DIN912 M4x25 mm Sst.	4					10
35	12.5019.31	Pilot lamp	1					5

** On request

Kit	P/N	Description	
K1	25.4320.24	Nozzle kit M4 - M21E 2x5pcs.	1
K2	25.4356.24	Seals Kit -M25E (S/No.1-100) 13x1pcs.	1
K3	25.4357.24	Seals Kit - M25E (S/No.101-518) 12x1pcs.	1
K4	25.4360.24	Seals Kit - M25E (S/No.519>) 13x1pcs.	1

(1) 25.4355.00 (2) 25.4350.00 (3) 25.4350.24 (4) 25.4350.25 (5) 25.4350.60

Pos.	P/N	Description	Q.ty	K1	K2	K3	K4	
36	12.5019.25	Cable, 1x0,75 L.250 mm	1					5
37	12.5016.10	On/off unipol. switch	1					3
38	12.5016.05	Switch protector	1					5
39	13.5997.00	Cable gland 1/4 +protection	1					5
40	12.5019.47	Wire tap-in	1					5
41	12.5019.10	Cable, 2x1,5 mm 10m+F connection	1					5
42	12.5071.00	Transf. 230VAC/12VDC EU (2)	1					1
42	12.5071.24	Transf. 240VAC/12VDC AUS (3)	1					1
42	12.5071.25	Transf. 24VAC/12VDC EU (4)	1					1
42	12.5071.60	Transf. 115VAC-60Hz/12VDC USA (5)	1					1
43	80.0338.31	Coupl., M16x1 M brass+Ni	1					10
44	10.3179.10	O-ring, 2,62x13,94 mm Vi 70	1	•	•	•		10
45	80.0337.56	Intake tube, 1/4M Bsp 113mm Sst.	1					3
46	80.0344.85	Knob, 32x110mm PP black	1					5
47	80.0347.35	Hand nut, G3/4 brass+Ni	1					5
48	80.0346.35	Elbow+hose barb, 20mm brass+Ni	1					3
49	80.0336.31	Venturi fitting, brass+Ni	1					3
50	80.0335.81	Taper.ring,opn. 14x20x11mm POM white	1					10
51	80.0334.31	Ring nut, M24x1,5 brass+Ni	1					5
52	10.3109.95	O-ring, 2,4x9,3 mm Vi 70	2	•	•	•		25
53	80.0333.31	Nozzle holder, 3/8M Bsp brass+Ni	1					3
54	25.0019.51	Nozzle, 02 d.10,5x15 mm Sst.	1					5
55	10.3052.00	O-ring, 1,78x6,75 mm	1	•	•	•		25
56	80.0348.31	Coupl., 3/8M Bsp-M22x1 M brass+Ni	1					3
57	80.0349.35	T-fitting, 3/8Bsp FFF brass+Ni	1					3
58	80.0402.31	Slide valve, 3/8M-1/4M Bsp brass	1					3
59	80.0403.21	Knob, PA black + Insert, brass	1					3
60	29.0402.51	Snap ring, 1,6x14,3 mm Sst.	1					5
61	10.3058.10	O-ring, 1,78x10,82 mm Vi 70	3			•		10
62	10.4058.00	Back-up ring, opn. 14x16x2 mm	3			•		10
63	80.0400.00	Flow regulator -RF1, 3/8M -1/4M Bsp	1					3
64	26.0252.51	Snap ring, 1,5x15,5 mm Sst.	1					10
65	26.0261.31	Plug, 14mm-1/4F Bsp brass	1					10
66	26.0260.22	Hand nut, M22x1,5 - 17,5mm black	1					10
67	10.4010.01	Back-up ring, opn. 10,2x13,9x1,2 mm	1	•	•	•		50
68	25.4320.24	Nozzle kit M4 - M21E 2x5pcs.	1					1
69	25.4353.20	Exten.-M21E 20m 12V DC MF **	1					1
70	80.0380.00	Suction tube, for Ø940mm barrel **	1					1
70	80.0386.00	Suction tube, for Ø1070mm barrel **	1					1
71	10.3066.10	O-ring, 1,78x15,6 mm Vi 70	2		•			10
75	14.3911.00	Washer, 13,5x19x1,5 mm Cu	1					10
76	14.6552.00	Teflon silicon grease *30g. **	1					2

Pos.	Codice	Descrizione	Q.tà	K1	K2	K3	K4	Pos.	Codice	Descrizione	Q.tà	K1	K2	K3	K4
1	80.0330.81	Respingente forato POM bianco	1				5	38	12.5016.05	Protezione interruttore	1				5
2	80.0367.51	Racc. M16x1 M inox	1				1	39	13.5997.00	Pressacavo 1/4 +protezione	1				5
3	80.0328.51	Ghiera G1/4F inox	1				5	40	12.5019.47	Rubacorrente	1				5
4	80.0327.51	Perno porta guarnizioni inox	1				5	41	12.5019.10	Cavo 2x1,5 mm 10m+connessione F	1				5
5	10.3010.10	An.OR 1x18 mm Vi 70	2	•			10	42	12.5071.00	Trasf. 230Vca/12Vcc EU (1)	1				1
6	80.0331.51	Statore inox	1				1	42	12.5071.24	Trasf. 240Vca/12Vcc AUS (2)	1				1
7	80.0325.51	Perno M10x1 inox	1				1	42	12.5071.25	Trasf. 24Vca/12Vcc EU (3)	1				1
8	10.3055.10	An.OR 1,78x7,66 mm Vi 70	1	•			10	42	12.5071.60	Trasf. 115Vca-60Hz/12Vcc USA (4)	1				1
9	15.3704.00	Tappo M4 plast.	2				4	43	80.0338.31	Racc. M16x1 M ott.+Ni	1				10
9	80.0350.51	Ugello 02 - 1,0mm - M4 inox verde ch.	2	•			10	44	10.3179.10	An.OR 2,62x13,94 mm Vi 70	1	•			10
9	80.0351.51	Ugello 025 - 1,1mm - M4 inox rosa	2	•			10	45	80.0337.56	Tube aspirazione G1/4M 113mm inox	1				3
9	80.0352.51	Ugello 03 - 1,2mm - M4 inox bianco	2	•			10	46	80.0344.85	Manopola 32x110mm PP nera	1				5
9	80.0353.51	Ugello 035 - 1,3mm - M4 inox marrone	2	•			10	47	80.0347.35	Girello G3/4 ott.+Ni	1				5
9	80.0354.51	Ugello 04 - 1,4mm - M4 inox giallo	2	•			10	48	80.0346.35	Gomito ptgm 20mm ott.+Ni	1				3
10	10.2030.00	Guarn. stelo 15x20x2,2 mm +OR	2	•			4	49	80.0336.31	Racc. venturi ott.+Ni	1				3
11	80.0326.51	Pignone portaug. z.41 M4 FF inox	1				3	50	80.0335.81	An.conico a. 14x20x11mm POM bianco	1				10
12	10.2030.18	Guarn. stelo 18x23x2 mm +OR Epdm	3	•			5	51	80.0334.31	Ghiera M24x1,5 ott.+Ni	1				5
13	80.0024.85	Boccola a. 18x22x14,8mm PTFE	1				5	52	10.3109.95	An.OR 2,4x9,3 mm Vi 70	2	•			25
14	10.3026.10	An.OR 1,5x20 mm Vi 70	1	•			10	53	80.0333.31	Racc. porta ugello G3/8M ott.+Ni	1				3
15	80.0372.23	Pignone z.34 inox+Boccola a.15mm PTFE	1				3	54	25.0019.51	Ugello 02 d.10,5x15 mm inox	1				5
16	80.0365.84	Tappo conico corto TPEs nero	1				3	55	10.3052.00	An.OR 1,78x6,75 mm	1	•			25
17	80.0316.84	Ghiera PP nera	1				10	56	80.0348.31	Racc. G3/8M-M22x1 M ott.+Ni	1				3
18	80.0364.56	Tube G1/4 MM 420mm inox	1				3	57	80.0349.35	Racc. a T G3/8 FFF ott.+Ni	1				3
19	10.3007.10	An.OR 1x12 mm Vi 70	2	•			25	58	80.0402.31	Racc. distrib. G3/8M-G1/4M ott.	1				3
20	80.0362.21	Tube 322mm + raccordo M22 inox	1				3	59	80.0403.21	Manopola PA nera + Insetto ott.	1				3
21	80.0012.51	Ghiera M28x1 inox	1				1	60	29.0402.51	An. elast. 1,6x14,3 mm inox	1				5
22	10.3205.10	An.OR 2,62x26,64 mm Vi 70	1	•			10	61	10.3058.10	An.OR 1,78x10,82 mm Vi 70	3	•			10
23	80.0321.51	Albero di trasmissione inox	1				1	62	10.4058.00	An.tenuta 14x16x2 mm	3	•			10
24	80.0341.21	Collettore inox	1				2	63	80.0400.00	Regolat. di portata RF1 G3/8M-G1/4M	1				3
25	11.4513.10	Dado es. M4 inox	4				10	64	26.0252.51	An. elast. 1,5x15,5 mm inox	1				10
26	11.4412.28	Cuscinetto 12x28x8 mm - 2RS1 inox	1				3	65	26.0261.31	Spinotto 14mm-G1/4F ott.	1				10
27	16.1860.00	Vite DIN912 M4x60 mm inox	2				10	66	26.0260.22	Girello M22x1,5 17,5mm nero	1				10
28	80.0318.41	Flangia motore	1				3	67	10.4010.01	An. anties. a. 10,2x13,9x1,2 mm	1	•			50
29	10.0999.05	An. elast. E 12 inox	1				10	68	25.4320.24	Kit Ugelli M4 - M21E 2x5pz.	1				1
30	80.0317.88	Guarniz. per motore, NBR	1				2	69	80.0371.21	Molla inox	1				1
31	15.1030.00	Spina elast. 3x16 mm inox	1				10	70	80.0370.86	Tube 10x12, 339mm PA bianco	1				1
32	13.0827.00	Motoriduttore 12V 10Rpm	1				1	71	80.0366.51	Racc. aspiraz. G1/4F-M16x1 M inox	1				1
33	80.0301.84	Carter motore PA nero	1				1	72	25.4353.20	Prol. -M21E 20m 12Vcc MF **	1				1
34	16.1856.00	Vite DIN912 M4x25 mm inox	4				10	73	25.4367.24	Kit tubo aspirante M25E, 6x1pz.	1				1
35	12.5019.31	Lampada spia	1				5	74	14.3911.00	Rosetta 13,5x19x1,5 mm Cu	1				10
36	12.5019.25	Cavo 1x0,75 L.250 mm	1				5	75	14.6552.00	Grasso silicone al teflon x30g. **	1				2
37	12.5016.10	Interr.unipol. on/off	1				3								

** Su richiesta

Kit	Codice	Descrizione	
K1	25.4320.24	Kit Ugelli M4 - M21E 2x5pz.	1
K2	25.4360.24	Kit ric.guarn. M25E (mat.519>) 13x1pz.	1

(1) 25.4363.00 (2) 25.4363.24 (3) 25.4363.25 (4) 25.4363.60

25.4363.00 M25E Barrel cl.,elect.driv+suct.,flex.
25.4363.24 M25E Barrel cl.,el.driv+suct.,flex. AUS

25.4363.25 M25E Barrel cl.,elect.driv+suct.,flex.
25.4363.60 M25E Barrel cl.,el.driv+suct.,flex.USA

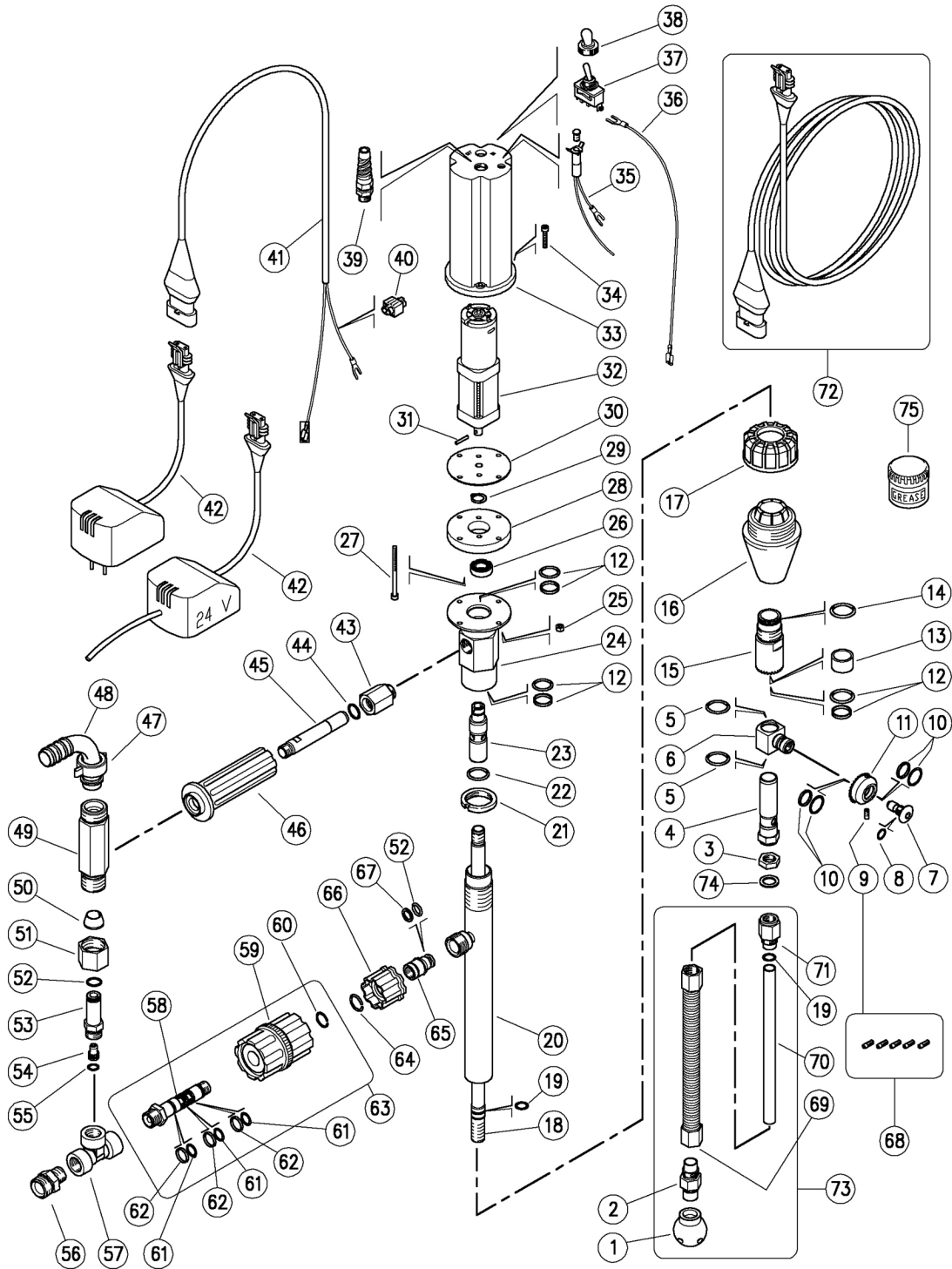

Pos.	P/N	Description	Q.ty	K1	K2	K3	K4	
1	80.0330.81	Pierced buffer, POM white	1					5
2	80.0367.51	Coupl., M16x1 M Sst.	1					1
3	80.0328.51	Ring nut, 1/4F Bsp Sst.	1					5
4	80.0327.51	Seal holding pin, Sst.	1					5
5	10.3010.10	O-ring, 1x18 mm Vi 70	2	•				10
6	80.0331.51	Stator, Sst.	1					1
7	80.0325.51	Pin, M10x1 Sst.	1					1
8	10.3055.10	O-ring, 1,78x7,66 mm Vi 70	1	•				10
9	15.3704.00	Plug, M4 plast.	2					4
9	80.0350.51	Nozzle, 02 - 1,0mm - M4 Sst. light green	2	•				10
9	80.0351.51	Nozzle, 025 - 1,1mm - M4 Sst. pink	2	•				10
9	80.0352.51	Nozzle, 03 - 1,2mm - M4 Sst. white	2	•				10
9	80.0353.51	Nozzle, 035 - 1,3mm - M4 Sst. brown	2	•				10
9	80.0354.51	Nozzle, 04 - 1,4mm - M4 Sst. yellow	2	•				10
10	10.2030.00	Stem seal, 15x20x2,2 mm +O-ring	2	•				4
11	80.0326.51	Nzl hold. pinion, z.41 M4 FF Sst.	1					3
12	10.2030.18	Stem seal, 18x23x2 mm +O-ring Epdm	3	•				5
13	80.0024.85	Bushing, opn. 18x22x14,8mm PTFE	1					5
14	10.3026.10	O-ring, 1,5x20 mm Vi 70	1	•				10
15	80.0372.23	Pinion, z.34 Sst.+bushing,opn.15mm PTFE	1					3
16	80.0365.84	Tapered plug, short TPEs black	1					3
17	80.0316.84	Ring nut, PP black	1					10
18	80.0364.56	Tube, 1/4Bsp MM 420mm Sst.	1					3
19	10.3007.10	O-ring, 1x12 mm Vi 70	2	•				25
20	80.0362.21	Tube, 322mm + coupling, M22 Sst.	1					3
21	80.0012.51	Ring nut, M28x1 Sst.	1					1
22	10.3205.10	O-ring, 2,62x26,64 mm Vi 70	1	•				10
23	80.0321.51	Propeller shaft, Sst.	1					1
24	80.0341.21	Manifold, Sst.	1					2
25	11.4513.10	Hex. nut, M4, Sst.	4					10
26	11.4412.28	Ball-bearing, 12x28x8 mm - 2RS1 Sst.	1					3
27	16.1860.00	Screw, DIN912 M4x60 mm Sst.	2					10
28	80.0318.41	Motor flange	1					3
29	10.0999.05	Snap ring, E 12 Sst.	1					10
30	80.0317.88	Motor seal, NBR	1					2
31	15.1030.00	Roll pin, 3x16 mm Sst.	1					10
32	13.0827.00	Gearmotor, 12V 10Rpm	1					1
33	80.0301.84	Motor casing, PA black	1					1
34	16.1856.00	Screw, DIN912 M4x25 mm Sst.	4					10
35	12.5019.31	Pilot lamp	1					5
36	12.5019.25	Cable, 1x0,75 L.250 mm	1					5
37	12.5016.10	On/off unipol. switch	1					3

** On request

Kit	P/N	Description	
K1	25.4320.24	Nozzle kit M4 - M21E 2x5pcs.	1
K2	25.4360.24	Seals Kit - M25E (S/No.519>) 13x1pcs.	1

(1) 25.4363.00 (2) 25.4363.24 (3) 25.4363.25 (4) 25.4363.60

Pos.	P/N	Description	Q.ty	K1	K2	K3	K4	
38	12.5016.05	Switch protector	1					5
39	13.5997.00	Cable gland 1/4 +protection	1					5
40	12.5019.47	Wire tap-in	1					5
41	12.5019.10	Cable, 2x1,5 mm 10m+F connection	1					5
42	12.5071.00	Transf. 230VAC/12VDC EU (1)	1					1
42	12.5071.24	Transf. 240VAC/12VDC AUS (2)	1					1
42	12.5071.25	Transf. 24VAC/12VDC EU (3)	1					1
42	12.5071.60	Transf. 115VAC-60Hz/12VDC USA (4)	1					1
43	80.0338.31	Coupl., M16x1 M brass+Ni	1					10
44	10.3179.10	O-ring, 2,62x13,94 mm Vi 70	1	•				10
45	80.0337.56	Intake tube, 1/4M Bsp 113mm Sst.	1					3
46	80.0344.85	Knob, 32x110mm PP black	1					5
47	80.0347.35	Hand nut, G3/4 brass+Ni	1					5
48	80.0346.35	Elbow+hose barb, 20mm brass+Ni	1					3
49	80.0336.31	Venturi fitting, brass+Ni	1					3
50	80.0335.81	Taper.ring,opn. 14x20x11mm POM white	1					10
51	80.0334.31	Ring nut, M24x1,5 brass+Ni	1					5
52	10.3109.95	O-ring, 2,4x9,3 mm Vi 70	2	•				25
53	80.0333.31	Nozzle holder, 3/8M Bsp brass+Ni	1					3
54	25.0019.51	Nozzle, 02 d.10,5x15 mm Sst.	1					5
55	10.3052.00	O-ring, 1,78x6,75 mm	1	•				25
56	80.0348.31	Coupl., 3/8M Bsp-M22x1 M brass+Ni	1					3
57	80.0349.35	T-fitting, 3/8Bsp FFF brass+Ni	1					3
58	80.0402.31	Slide valve, 3/8M-1/4M Bsp brass	1					3
59	80.0403.21	Knob, PA black + Insert, brass	1					3
60	29.0402.51	Snap ring, 1,6x14,3 mm Sst.	1					5
61	10.3058.10	O-ring, 1,78x10,82 mm Vi 70	3	•				10
62	10.4058.00	Back-up ring, opn. 14x16x2 mm	3	•				10
63	80.0400.00	Flow regulator -RF1, 3/8M -1/4M Bsp	1					3
64	26.0252.51	Snap ring, 1,5x15,5 mm Sst.	1					10
65	26.0261.31	Plug, 14mm-1/4F Bsp brass	1					10
66	26.0260.22	Hand nut, M22x1,5 - 17,5mm black	1					10
67	10.4010.01	Back-up ring, opn. 10,2x13,9x1,2 mm	1	•				50
68	25.4320.24	Nozzle kit M4 - M21E 2x5pcs.	1					1
69	80.0371.21	Spring, Sst.	1					1
70	80.0370.86	Hose, 10x12, 339mm PA white	1					1
71	80.0366.51	Suction coupl., 1/4F Bsp-M16x1 M Sst.	1					1
72	25.4353.20	Exten.-M21E 20m 12V DC MF **	1					1
73	25.4367.24	Suction tube kit -M25E, 6x1pcs.	1					1
74	14.3911.00	Washer, 13,5x19x1,5 mm Cu	1					10
75	14.6552.00	Teflon silicon grease *30g. **	1					2