



## P.A. - S.p.A. - EQUIPAGGIAMENTI TECNICI DEL LAVAGGIO

VIA MILANO, 13 - CASELLA POSTALE 115 - 42048 RUBIERA (REGGIO EMILIA) - ITALY  
 Tel. +39 0522 623611 - Fax. +39 0522 629600 - R.E.A. RE 156319 - R. I. RE 11535 - Mecc. RE 013446  
 C.F. e P. IVA 01035950359 - Cap. Soc. i.v. € 750.000,00 - Codice Identificativo C.E.E. IT 01035950359  
 ART. 2497 - BIS C.C. DIREZIONE E COORDINAMENTO BENETTI srl R.I. TRIB. DI RE 01480690351  
<http://www.pa-etl.it> - E-mail: [info@pa-etl.it](mailto:info@pa-etl.it)



## FL7 – Electric signal flow switch usable also for intake

### Technical manual: E 823-04

Electro-mechanical device in which the fluid passage moves a magnetized piston that opens an electric circuit.

DN 10



- **28.0400.10** G3/8 FF 350 bar – 35 MPa - BLACK
- **28.0400.38** G3/8 FF 350 bar – 35 MPa - BLACK
- **28.0450.00** G3/8 FF 500 bar – 50 MPa - INOX BLUE

- Magnetic drive obtained by the plunging piston movement
- Electrical insulation: class IP55
- Magnetic probe casing made of antiframe material.
- Block press of plastic material which prevents the bending and rupture of the electric cable.

### TECHNICAL SPECIFICATIONS

<b>Rated voltage:</b>	12 ÷ 230 V AC/DC	<b>Max. commutable power:</b>	60VA
<b>Cable length:</b>	1250 mm	<b>Electric wire:</b>	2 x 0,50mm <sup>2</sup>
<b>Max. current:</b>	3 A	<b>Type of action:</b>	1C

**Electrical component life:** from 100.000 to 1.000.000 commutations at max power

**Pollution situation of the device control:** High

PART NUMBER	PERMISSIBLE PRESSURE		MAX FLOW RATE IN PUMP DELIVERY (1)		MIN FLOW RATE HORIZONTAL INTERVENTION		MIN FLOW RATE VERTICAL INTERVENTION		MAX WORK TEMPERATURE (2)		WEIGHT		INLET OUTLET
	bar	psi	l/min	USG	l/min	USG	l/min	USG	°C	F	g	lbs	
28.0400.10	390	5650	60	16	6	1.6	9	2.4	50	120	430	0.9	G 3/8" F
28.0400.38	390	5650	60	16	3	0.8	4	1	50	120	430	0.9	G 3/8" F
28.0450.00	560	8100	60	16	6	1.6	9	2.4	50	120	430	0.9	G 3/8" F

(1) Max flow rate allowed for use in pump intake: **30 l/min (8 USGpm)**

(2) This product has been designed for a continuous use at water temperature of 50 °C .  
 It can resist for short periods at a maximum temperature of **80 °C (175 F)**

## DIMENSIONAL DRAWING

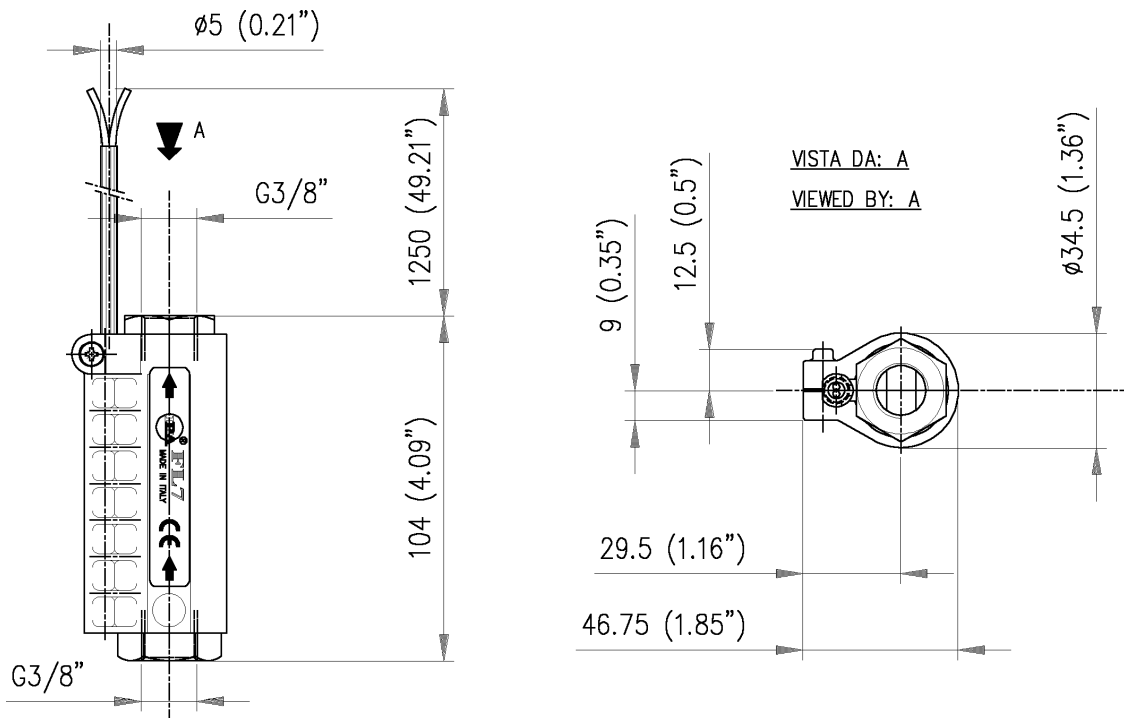

## SELECTION

This product is to be utilized with clean fresh water, even slightly additivated with normal detergents. For use involving different or corrosive liquids, contact the PA Technical department.

Choose the flow switch in line with the work data of the system (max pressure, max flow and max temperature of the system) . In any case, the pressure of the machine must not exceed the **permissible pressure** imprinted on the flow switch.

Verify also the real value of voltage and current of the system: they have to be kept within the indicated max value.

## FUNCTION

The flow switch detects the presence of water flow on the inside of the system by means of a piston which is shifted by the water itself. When the piston is moved by the water flow, the magnets contained internally, stimulate a reed switch that closes the electric circuit.

## INSTALLATION

This accessory can be installed horizontally or vertically. The water flow has to be directed as per the direction of the arrows inscribed on the plastic casing of the flow switch.

### Connection to the Hydraulic system.

Use correct fittings in line with the system performance. Avoid restrictions on the passage diameters that may cause malfunctions. This accessory, on a machine that produces hot water, must be fitted upstream of the heat generator.

This product is to be installed on a finished machine.

### Connection to the Electric circuit.

For the connection of the electric circuit, see **fig. 1**

Electrical installation is to be carried out by qualified personnel.

This product must be fitted on an earthed hydraulic system.

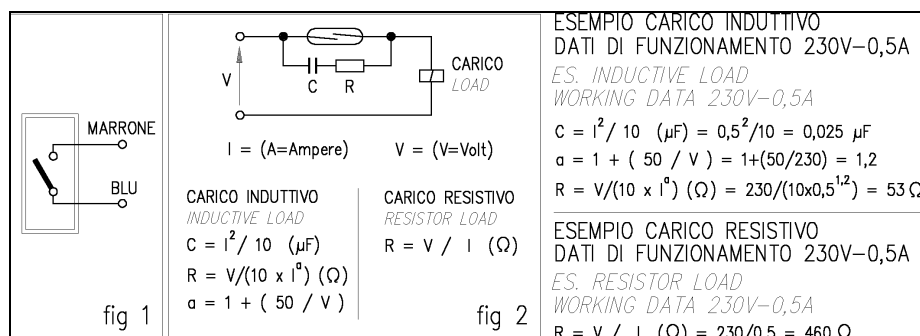

## ELECTRICAL LIFETIME OF THE CONTACT

The electric circuit, contained in the probe, consists of a reed switch that can function up to 1 million operations. Current or Voltage in excess, superior to the allowed limits, damage considerably the contacts reducing the electric lifetime (pitting; sticking). To prevent these phenomena, it is necessary to evacuate with attention the transient situations in which the take off current might be 10/12 times the normal current. Even the interruption of inductive loads can make the circuit reach high voltage readings in the order of thousands of volts. Therefore, take care in these situations of overload and excess voltage which are created during starting with the circuit closure (start current) and, at closure, with the circuit aperture (detached tension).

In order to prevent these distortions it is necessary to install adequate protections for the system. There are many circuits to choose from and one of the most common with effective remedy is seen on **fig.2**.

In order to prevent malfunctions, the flow switch must not be set near heat or magnetic sources. Do not store or handle on full metal structures nor test the magnetic strength of the piston on magnetic material. It is advisable to properly clean the system before operation in order to expel possible residual metal in case found in the tubes. The electric probe is stamped at the end of the exit cable, indicating the setting in relation to the brass body and allows a correct assembly of the "reed" bulb. In case of intervention or repair, follow this indication: incorrect positioning could damage the probe.

## PROBLEMS AND SOLUTIONS

PROBLEMS	PROBABLE CAUSES	SOLUTIONS
The piston does not move	<ul style="list-style-type: none"> <li>- Insufficient flow</li> <li>- Incorrect flow direction</li> <li>- Piston jammed by scale and debris</li> </ul>	<ul style="list-style-type: none"> <li>- Check and eliminate eventual leaks in the line</li> <li>- Reassemble and respect the correct flow direction</li> <li>- Clean or replace</li> </ul>
No electric signal	<ul style="list-style-type: none"> <li>- Damaged electric contacts or "reed" switch</li> <li>- Electric connection incorrect or disconnected</li> <li>- Un-phased probe or displaced</li> </ul>	<ul style="list-style-type: none"> <li>- Replace electric probe; install protective circuit if absent</li> <li>- Renew</li> <li>- Renew in correct position</li> </ul>

## MAINTENANCE

Every 400 working hours or 10,000 cycles, check the magnetic pin (pos3 in exploded view) and clean. Use only original PA spares, in order to benefit for a correct function and long reliability.

Maintenance has to be carried out by specialized technicians.

**The Manufacturer is not to be considered responsible for damage as a result from incorrect fitting and maintenance.**

## REGULATIONS

See norm manual.

The accessory hereby described bears the CE marking in accordance with the Norms and Directives applied on the **Declaration of Conformity**.

For a correct utilization, follow the directions described in this manual and re-print them on the Use and maintenance manual of the machine.

Make sure that you are given the original Conformity Declaration for the accessory chosen. The present manual is valid for all Flow switches named **FL7**

Technical data, descriptions and illustrations are indicative and liable to modification without notice.

<b>Instruction manual, maintenance, installation, spare parts.</b> For a correct utilization follow the directions of this manual. <b>Re-print them on the use and maintenance booklet of the machine.</b>	n. 12.9803.04

28.0400.10 FL7 Flow switch 3/8FF Bsp

28.0400.38 FL7 Flow switch 3/8FF Bsp, 4 l/min

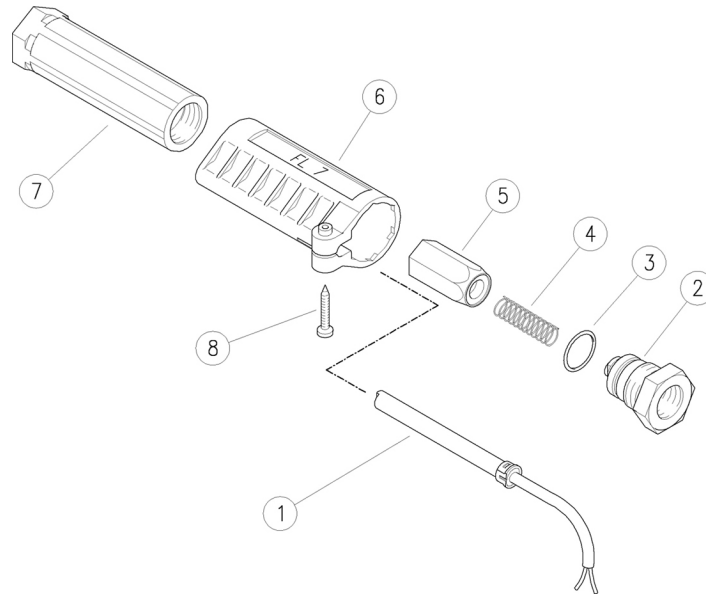

Pos.	P/N	Description	Q.ty	K1	K2	K3	K4	
1	28.0518.23	Feeler, 3A +1250 mm cable	1					5
2	28.0404.31	Fl/sw. coupl., M22x1,5M-3/8F Bsp brass	1					3
3	10.3066.01	O-ring, 1,78x15,6 mm Ni 85	1					10
4	28.0406.51	Spring, 0,4x8,4x33 mm Sst.	1					5
5	28.0410.23	Magnet holder, brass	1					5

Pos.	P/N	Description	Q.ty	K1	K2	K3	K4	
5	28.0418.23	Magnet holder, brass (1)	1					5
6	28.0408.84	Flow switch housing, PA	1					5
7	28.0401.31	Fl/sw. housing, M22x1,5F-3/8F Bsp brass	1					3
8	16.3021.18	S/tapping screw, DIN7981 2,5x16 mm	1					10

(1) 28.0400.38